



P1M Series

Extra Low Profile Pneumatic Cylinder

Section J



J

Features	J2	Double Rod Style C & J	J14
Ordering Information.....	J3	Double Rod Style F	J15
Specifications	J4	Rod End Accessories	J16-J17
Technical Data.....	J5	Service Kits	J18
Dimensions.....	J6-J13		



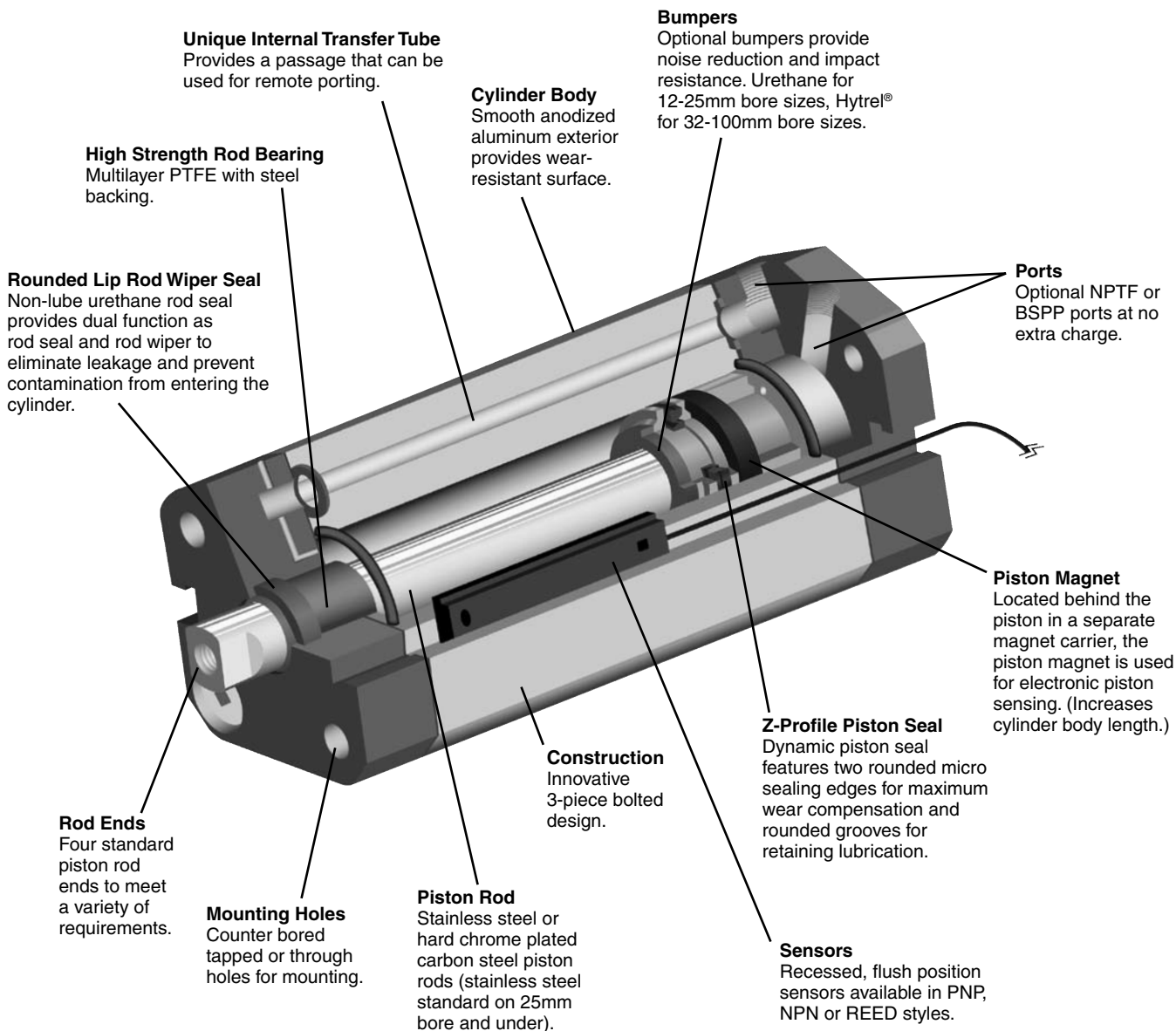

Hytrel® is a registered trademark of DuPont.

Extra Low Profile Version

The Extra Low Profile Bearing Version allows us to provide the most compact cylinder possible. This bearing version is recommended for applications that require shorter stroke lengths or that are light duty. It is available in stroke lengths up to 50mm in the smaller bore sizes and 150 mm in the larger bore sizes.

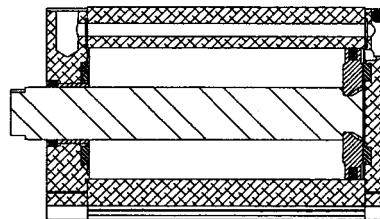

Long Bearing Version

The Long Bearing Version provides additional rod bearing and piston bearing support and also includes a magnetic piston with bearing strip for greater piston bearing support. This Long Bearing version is required for stroke lengths beyond the Extra Low Profile maximum stroke length and is recommended for higher duty applications.

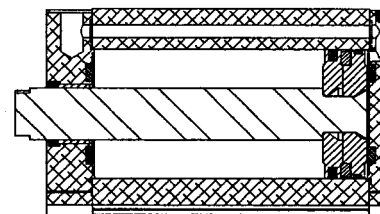

How to Order P1M Series Cylinders

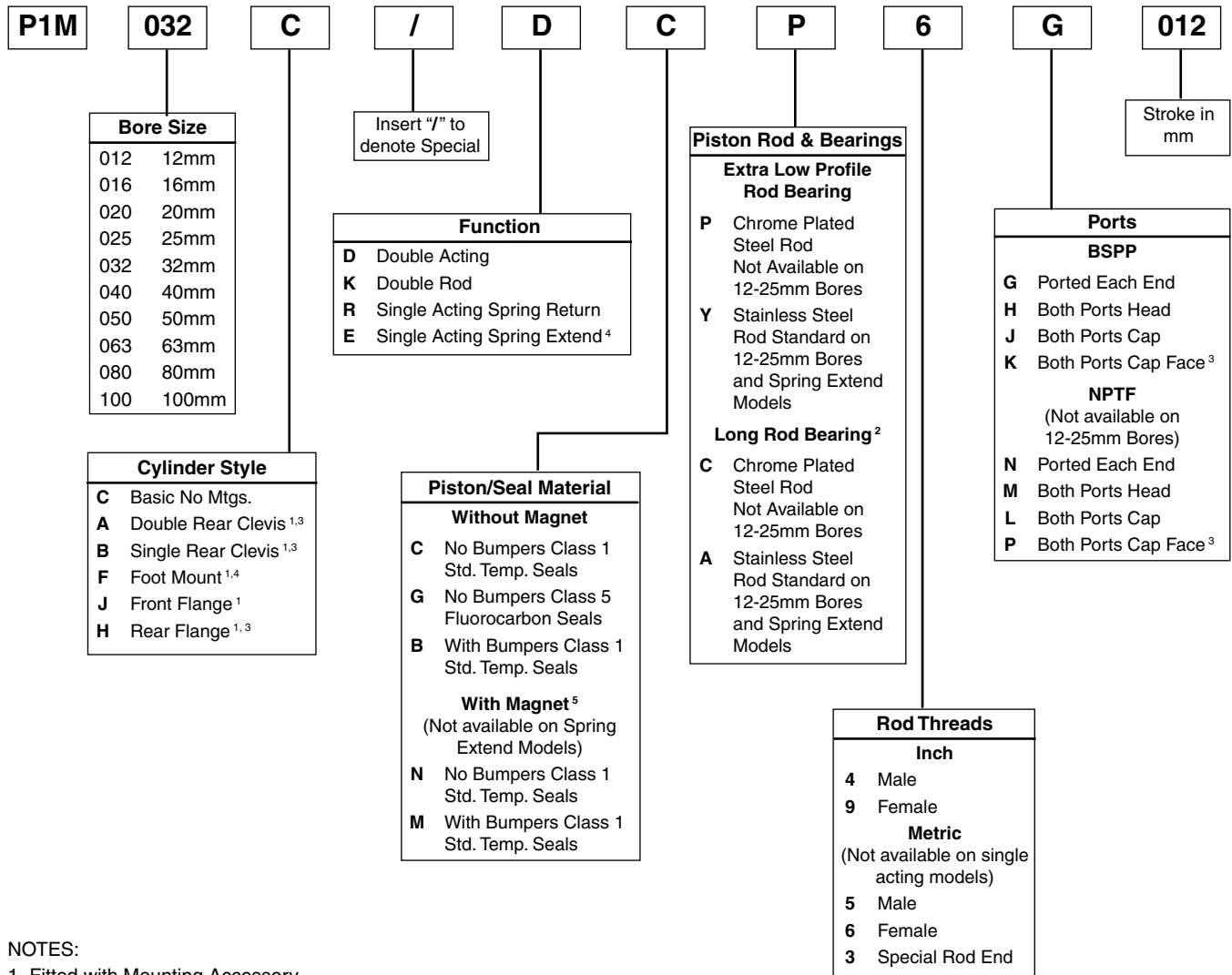

NOTES:

- 1 Fitted with Mounting Accessory
- 2 Magnetic Piston Option must be specified along with Long Rod Bearing option to achieve Long Bearing Version
- 3 Porting Options 'K' and 'P' (Both ports cap face) not available with rear mountings
- 4 Single Acting Spring Extend available with stainless steel rod only.
- 5 For information regarding sensors, please refer to Electronic Sensors section.

Maximum Stroke Lengths

Bore	ELP Bearing Version		Long Bearing Version	
	Min. Stroke*	Max. Stroke	Min. Stroke*	Max. Stroke
12	3	50	4	200
16	3	50	4	200
20	3	50	8	200
25	3	50	8	200
32	3	100	9	320
40	3	100	7	320
50	3	100	13	320
63	3	100	18	500
80	3	150	23	500
100	3	150	18	500

* Minimum Stroke for Double Rod cylinders: 12-63mm Bores is 5mm
 80 & 100mm Bores is 10mm



Material Specifications¹

Piston Rod	12mm to 25mm bores: Stainless Steel 32mm to 100mm bores: Chrome Plated Carbon Steel Std., Optional Stainless Steel (Stainless Steel std. on single-acting spring extend)
Piston Rod Seal	Polyurethane
Piston Rod Bearing ²	Multilayer PTFE with Steel Backing
End Covers	Anodized Aluminum Alloy
Assembly Cap Screws	Stainless Steel / Zinc-Plated Steel
O-Rings	Nitrile Rubber, NBR
Cylinder Body	Anodized Aluminum Alloy
Piston	Aluminum Alloy
Piston Seal	Nitrile Rubber, NBR
Magnetic Piston Bearing ³	Brass (12-25mm) Nylon (32-100mm)
Magnet	Plastic Coated Magnetic Material
Bumpers	Polyurethane
Return Spring	Chrome Silicon Wire

High Temperature Option

O-Rings	Fluorocarbon, FPM
Piston Rod Seal	Fluorocarbon, FPM
Piston Seal	Fluorocarbon, FPM

Additional Data

Working Pressure	Max. 10 Bar Air
Standard Temperature	-20°C to +80°C -4°F to +176°F
High Temperature Service	-10°C to +121°C +14°F to 250°F

¹ Dimensions not otherwise noted are listed in millimeters (mm)
² Excludes 12-25mm bore Rod Style Y
³ Magnetic Piston option is not available on Spring Extend models.

Single Acting Cylinders

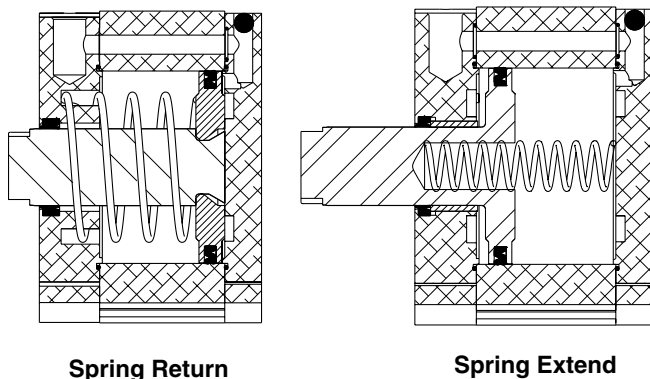

Bore (mm)	Return Loads		Extend Loads		Standard Stroke Lengths (mm) ²
	Max (lbs)	Min (lbs)	Max (lbs)	Min (lbs)	
12	2.8	1.0	2.5	1.1	5,10
16	3.5	1.5	4.0	2.0	5,10
20	3.5	1.5	5.0	2.5	5,10
25	4.7	2.5	6.0	2.5	5,10
32	6.0	3.5	6.5	4.0	5,10
40	7.2	4.7	7.0	4.0	5,10
50	14.3	6.0	18.0	8.0	10, 20, 25
63	14.3	6.0	18.0	8.0	10, 20, 25
80	26.0	14.0	25.0	10.0	10, 20, 25
100	26.0	14.0	25.0	10.0	10, 20, 25

Additional Length for Bumper Option

Bore	Double Acting*		Single Acting**	
	Single Rod	Double Rod	Spring Return	Spring Extend
12	1.4	2.0	–	1.0
16	1.6	2.0	0.6	1.0
20	2.2	3.0	0.7	1.5
25	2.2	3.0	0.7	1.5
32	1.0	1.0	–	–
40	1.0	1.0	–	–
50	0.8	0.8	–	–
63	1.0	1.0	–	–
80	0.8	0.8	–	–
100	1.0	1.0	–	–

* Bumpers at both ends
** Bumpers at end opposite of spring only.

NOTES:

- Overall Length to be the same as double-acting models with comparable bearing, piston and porting configuration.
- Single-acting cylinders are available in standard stroke lengths. Custom stroke lengths are available upon request.
- Spring Extend cylinders available with stainless steel rod only.
- Magnetic Piston Option is not available on Spring Extend Models.

Forces, Weights, Air Consumption

Bore (mm)	Area (cm ²)	Piston Rod		Extend Force* (N)	Retract Force* (N)	Weight		Air Consumption (Liters)**
		Dia. (mm)	Area (cm ²)			Zero Stroke (kg)	Per 10mm Stroke (kg)	
12	1.13	6	0.28	67	50	0.060	0.016	0.0139
16	2.01	8	0.50	120	91	0.090	0.022	0.0246
20	3.14	10	0.78	188	142	0.150	0.032	0.0385
25	4.91	10	0.78	294	247	0.170	0.034	0.0633
32	8.0	12	1.1	482	414	0.260	0.044	0.1050
40	12.6	16	2.0	754	633	0.370	0.060	0.1620
50	19.6	20	3.1	1178	989	0.570	0.085	0.2530
63	31.2	20	3.1	1870	1681	0.860	0.098	0.4140
80	50.3	25	4.9	3016	2721	1.460	0.146	0.6690
100	78.5	25	4.9	4712	4417	2.390	0.155	1.0430

*Theoretical cylinder force at 600 kPa (6 bar).

** Free air consumption per 10mm stroke length for an extend and retract stroke at 600 kPa (6 bar)

Porting Configurations

Both Ports Cap

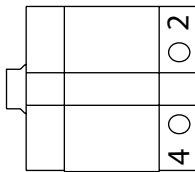

Both Ports Head*

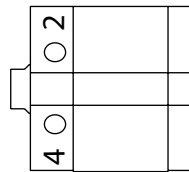

Both Ports Cap Face

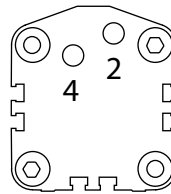

Double Rod Both Ports One End

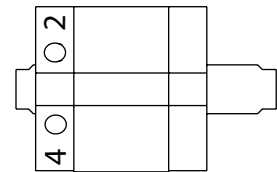

To retract cylinder apply air to port #2
 To extend cylinder apply air to port #4

For a double rod cylinder, pressurize port #2 to retract the piston rod into the head containing the ports.

*For 12mm to 16mm bores, although the location of ports #2 and #4 are reversed, porting functions shown above apply.



Front Profiles by Bore Size

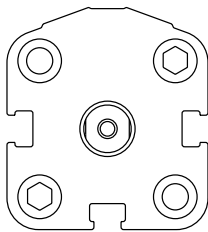

Bores 12-25mm

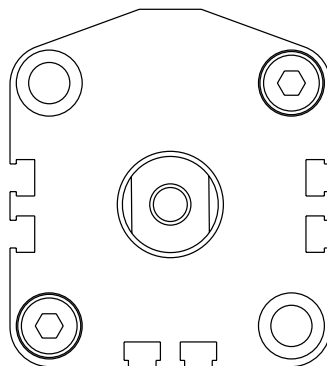

Bores 32-50mm

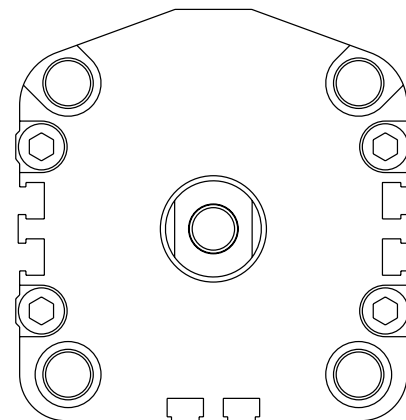

Bores 63-100mm

BOTH PORTS HEAD

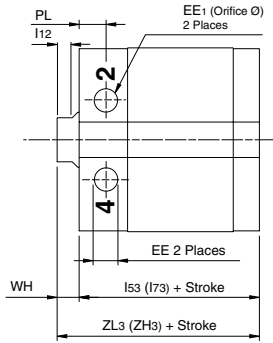

ALL PORTING CONFIGURATIONS

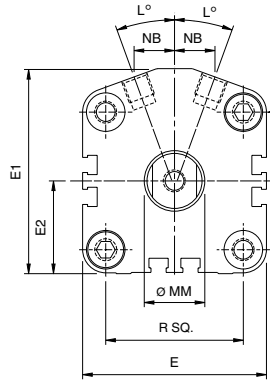

Bores 12-50mm:
(2) ØR₂ Thru,
180° Apart.
(4) ØR₁ C'Bore;
Bores 63-100mm:
(4) ØR₂ Thru,
(8) ØR₁ C'Bore

**MOUNTING HOLE CONFIGURATION
BOTH PORTS HEAD**

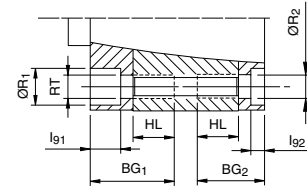

OPTIONAL PORTING CONFIGURATIONS

BOTH PORTS CAP

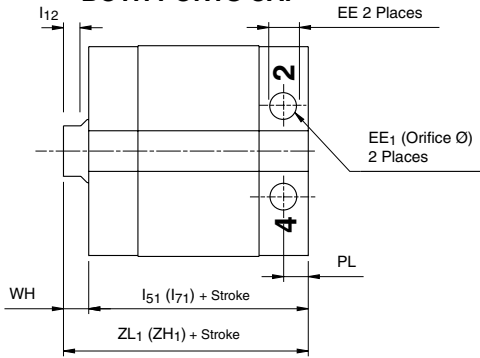

HEAD & CAP PORTED

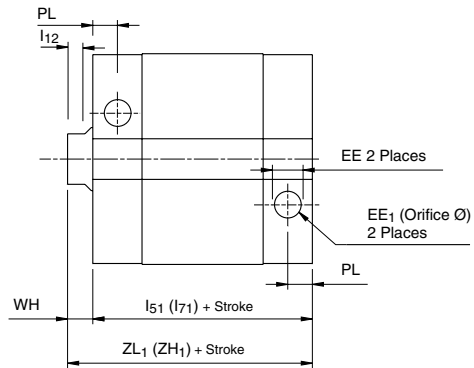

BOTH PORTS CAP FACE

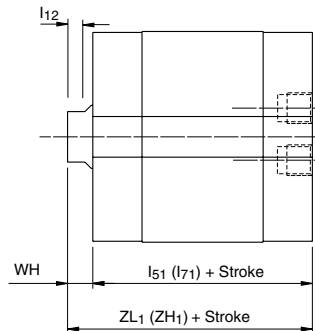
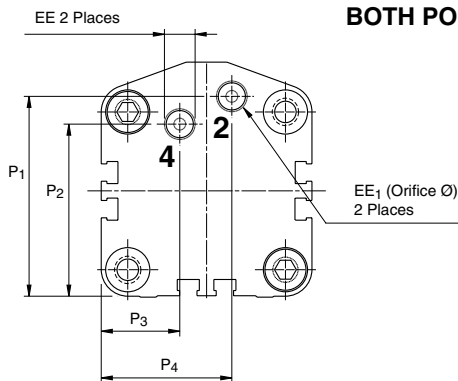

MOUNTING HOLE CONFIGURATION

**BOTH PORTS CAP OR CAP FACE,
PORTS AT HEAD & CAP**

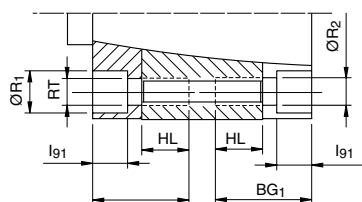

Note: Magnetic Dimensions in Parentheses

For special rod ends, specify "3" in model number and give desired WH, AM or AF and KK or KF.

Jam nut is supplied when cylinder is ordered with Style 4 or Style 5 rod end.

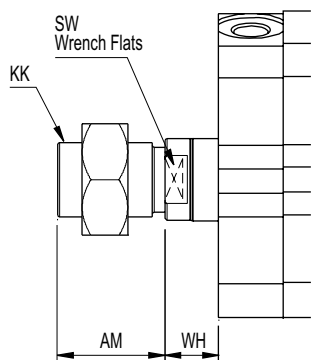

Style 5/Style 4

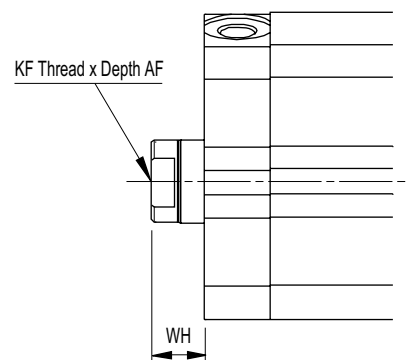

Style 6/Style 9

Bore	Rod	AF		AM		KF		KK		WH		I ₁₂	SW
		Style 6	Style 9	Style 5	Style 4	Style 6	Style 9	Style 5	Style 4	Style 4, 9 & 6	Style 5		
12	6	6	5.4	9	8	M3x0.5	#8-32	M5x0.8	#8-32	3.5	5	3	5
16	8	8	5.4	10	8	M4x0.7	#8-32	M6x1.0	#8-32	3.5	5.5	3	7
20	10	7	7	12	8	M5x0.8	#10-32	M8x1.25	#10-32	4.5	6.5	4	9
25	10	12	10	15	9.5	M6x1.0	1/4-28	M10x1.25	1/4-28	5	7.5	4	9
32	12	13	13.3	20.5	12.7	M8x1.25	5/16-24	M12x1.25	5/16-24	7	8	5	10
40	16	13	18.3	20.5	16	M8x1.25	3/8-24	M14x1.5	3/8-24	7	8	5.5	13
50	20	15	17.6	26	19.5	M10x1.5	1/2-20	M18x1.5	1/2-20	8	7.5	5.5	16
63	20	15	17.6	26	19.5	M10x1.5	1/2-20	M18x1.5	1/2-20	8	7.5	5.5	16
80	25	21	24.3	32.5	25.5	M16x2.0	5/8-18	M22x1.5	5/8-18	10	11	6	21
100	25	27	27	32.5	28.5	M20x2.5	3/4-16	M22x1.5	3/4-16	12	11	6	21

Bore	BG ₁	BG ₂	E	E ₁	E ₂	EE		EE ₁	HL	I ₉₁	I ₉₂	L	NB	P ₁	P ₂
						BSPP	NPTF								
12	16.5	11.5	27	31	14	M5	-	1	8	3.5	3.5	26	5.5	25	9.5
16	17	12	31.5	35	16	M5	-	1.2	8	4	4	20	7	29.5	9.5
20	19	14.5	38.5	42.5	19.5	M5	-	1.3	10	4.5	4.5	20	8	35	13.5
25	21	15	41.5	45.5	21	M5	-	1.8	10	5	5	20	8.5	38.5	14
32	25	17	48	56	24	G1/8	1/8	2.7	10	4	4	25	9.5	45.5	16.5
40	25.5	17.5	56	62.5	28	G1/8	1/8	3.4	10	4	4	20	11.5	51	12
50	29.5	23.5	67	74.5	33.5	G1/8	1/8	4	14	5	5	20	14.5	63	54.5
63	34	28	82	86	40.5	G1/8	1/8	5	18	6.5	8	20	17.5	73.5	64
80	43	34	98	106.5	48.5	G1/4	1/4	5.5	22	8.5	10	20	25.5	92	79.5
100	44	35.5	119	126.5	59.5	G1/4	1/4	6	22	8.5	10	20	31.5	111.5	97.5

Bore	P ₃	P ₄	PL	PM	R	R ₁	R ₂ *	RT	Non-Magnetic				Magnetic				ELP Max Stroke
									I ₅₁	I ₅₃	ZL ₁	ZL ₃	I ₇₁	I ₇₃	ZH ₁	ZH ₃	
12	13.5	13.5	5	8.5	15.5	5.8	3.5	M4	22	17	25.5	20.5	33	28	36.5	31.5	50
16	15.5	18	5	9	20	7.4	3.5	M4	23.5	18.5	27	22	34.5	29.5	38	33	50
20	24.5	21.5	5	9	25.5	9	5.5	M6	24	19.5	28.5	24	34	29.5	38.5	34	50
25	27.5	24.5	7	9	28	9	5.5	M6	28.5	22.5	33.5	27.5	38.5	32.5	43.5	37.5	50
32	31.5	28.5	8	10.5	34	10.5	5.5	M6	36.5	28.5	43.5	35.5	46	37.5	53	44.5	100
40	23	33	7.5	9.5	40	10.5	5.5	M6	37.5	29.5	44.5	36.5	47.5	39.5	54.5	46.5	100
50	25	41.5	8	10	50	13.5	7.5	M8	38.5	32.5	46.5	40.5	47.5	41.5	55.5	49.5	100
63	30	53	8	11	60	13.5	9.5	M10	39.5	34	47.5	42	51.5	46	59.5	54	100
80	33	69.5	11.5	11.5	77	16.5	11	M12	52	43	62	53	62.5	53.5	72.5	63.5	150
100	36.5	87.5	12	12	94	17	11	M12	57	48.5	69	60.5	71.5	63	83.5	75	150

**R2 thru not available on 12 and 16mm Bores.



BOTH PORTS HEAD

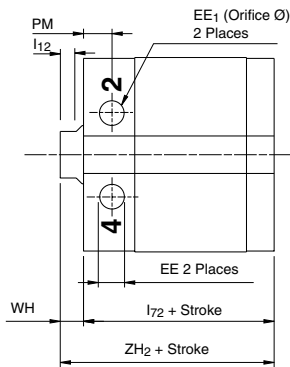

ALL PORTING CONFIGURATIONS

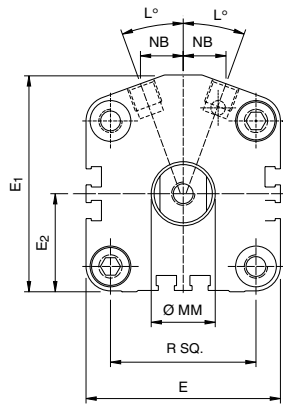

Bores 12-50mm:
(2) ØR₂ Thru,
180° Apart,
(4) ØR₁ C'Bore;
Bores 63-100mm:
(4) ØR₂ Thru,
(8) ØR₁ C'Bore

**MOUNTING HOLE CONFIGURATION
BOTH PORTS HEAD**

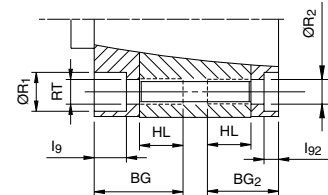

OPTIONAL PORTING CONFIGURATIONS

BOTH PORTS CAP

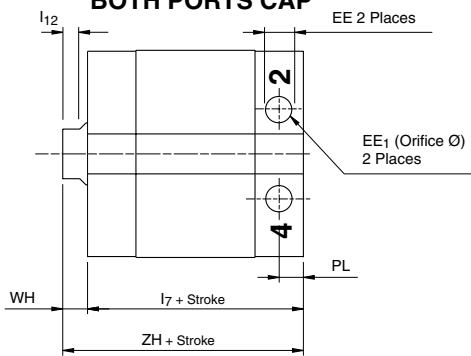

HEAD & CAP PORTED

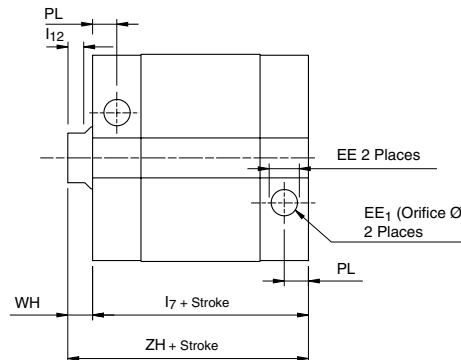

BOTH PORTS CAP FACE

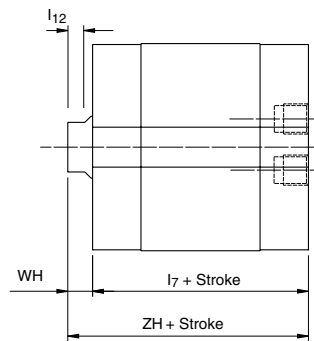
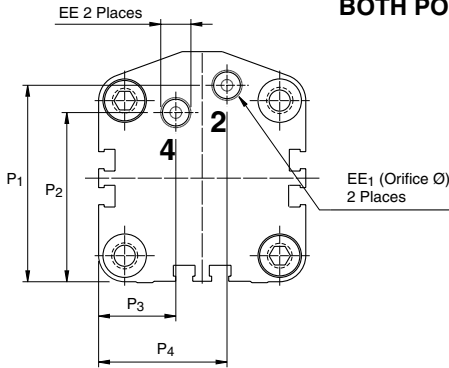

MOUNTING HOLE CONFIGURATION

**BOTH PORTS CAP OR CAP FACE,
PORTS AT HEAD & CAP**

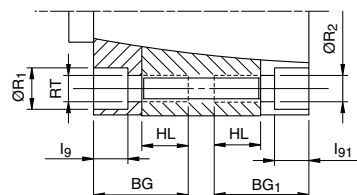

Dimensions Long Bearing Version

**Extra Low Profile Pneumatic Cylinders
P1M Series**

For special rod ends, specify "3" in model number and give desired WH, AM or AF and KK or KF.

Jam nut is supplied when Style 4 or Style 5 rod end is specified.

Note: Magnetic piston and longer rod bearing are standard with Long Bearing Version.

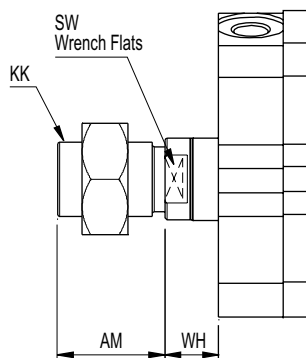

Style 5/Style 4

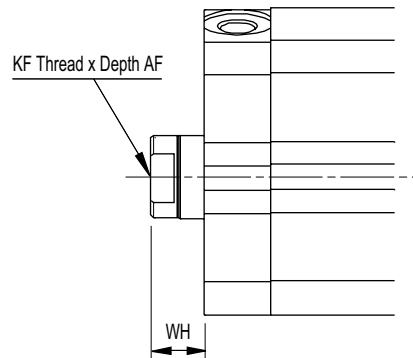

Style 6/Style 9

Bore	Rod MM	AF		AM		KF		KK		WH		I ₁₂	SW
		Style 6	Style 9	Style 5	Style 4	Style 6	Style 9	Style 5	Style 4	Style 4, 9 & 6	Style 5		
12	6	6	5.4	9	8	M3x0.5	#8-32	M5x0.8	#8-32	3.5	5	3	5
16	8	8	5.4	10	8	M4x0.7	#8-32	M6x1.0	#8-32	3.5	5.5	3	7
20	10	7	7	12	8	M5x0.8	#10-32	M8x1.25	#10-32	4.5	6.5	4	9
25	10	12	10	15	9.5	M6x1.0	1/4-28	M10x1.25	1/4-28	5	7.5	4	9
32	12	13	13.3	20.5	12.7	M8x1.25	5/16-24	M12x1.25	5/16-24	7	8	5	10
40	16	13	18.3	20.5	16	M8x1.25	3/8-24	M14x1.5	3/8-24	7	8	5.5	13
50	20	15	17.6	26	19.5	M10x1.5	1/2-20	M18x1.5	1/2-20	8	7.5	5.5	16
63	20	15	17.6	26	19.5	M10x1.5	1/2-20	M18x1.5	1/2-20	8	7.5	5.5	16
80	25	21	24.3	32.5	25.5	M16x2.0	5/8-18	M22x1.5	5/8-18	10	11	6	21
100	25	27	27	32.5	28.5	M20x2.5	3/4-16	M22x1.5	3/4-16	12	11	6	21

Bore	BG	BG ₁	BG ₂	E	E ₁	E ₂	EE		EE ₁	HL	I ₇	I ₇₂	I ₉	I ₉₁	I ₉₂	L
							BSPP	NPTF								
12	21.5	16.5	11.5	27	31	14	M5	-	1	8	38.5	33.5	3.5	3.5	3.5	26
16	22	17	12	31.5	35	16	M5	-	1.2	8	40.5	35.5	5.5	4	4	20
20	24.5	19	14.5	38.5	42.5	19.5	M5	-	1.3	10	40	35.5	10.5	4.5	4.5	20
25	24.5	21	15	41.5	45.5	21	M5	-	1.8	10	42.5	36.5	10.5	5	5	20
32	27.5	25	17	48	56	24	G1/8	1/8	2.7	10	48	40	14	4	4	25
40	27.5	25.5	17.5	56	62.5	28	G1/8	1/8	3.4	10	49.5	41.5	14	4	4	20
50	31.5	29.5	23.5	67	74.5	33.5	G1/8	1/8	4	14	49.5	43.5	13	5	5	20
63	37	34	28	82	86	40.5	G1/8	1/8	5	18	54.5	49	6.5	6.5	8	20
80	43	43	34	98	106.5	48.5	G1/4	1/4	5.5	22	62.5	53.5	9.5	8.5	10	20
100	44	44	35.5	119	126.5	59.5	G1/4	1/4	6	22	71.5	63	9.5	8.5	10	20

Bore	NB	P ₁	P ₂	P ₃	P ₄	PM	R	R ₁	R ₂ *	RT	ZH	ZH ₂	Min Stroke	Max Stroke
12	5.5	25	9.5	13.5	13.5	8.5	15.5	5.8	3.5	M4	42	37	4	200
16	7	29.5	9.5	15.5	18	9	20	7.4	3.5	M4	44	39	4	200
20	8	35	13.5	24.5	21.5	9	25.5	9	5.5	M6	44.5	40	8	200
25	8.5	38.5	14	27.5	24.5	9	28	9	5.5	M6	47.5	41.5	8	200
32	9.5	45.5	16.5	31.5	28.5	10.5	34	10.5	5.5	M6	55	47	9	320
40	11.5	51	12	23	33	9.5	40	10.5	5.5	M6	56.5	48.5	7	320
50	14.5	63	54.5	25	41.5	10	50	13.5	7.5	M8	57.5	51.5	13	320
63	17.5	73.5	64	30	53	11	60	13.5	9.5	M10	62.5	57	18	500
80	25.5	92	79.5	33	69.5	11.5	77	16.5	11	M12	72.5	62.5	23	500
100	31.5	111.5	97.5	36.5	87.5	12	94	17	11	M12	83.5	75	18	500

* "R2 thru" not available on 12 and 16mm Bores.



Foot Mounting – Style F

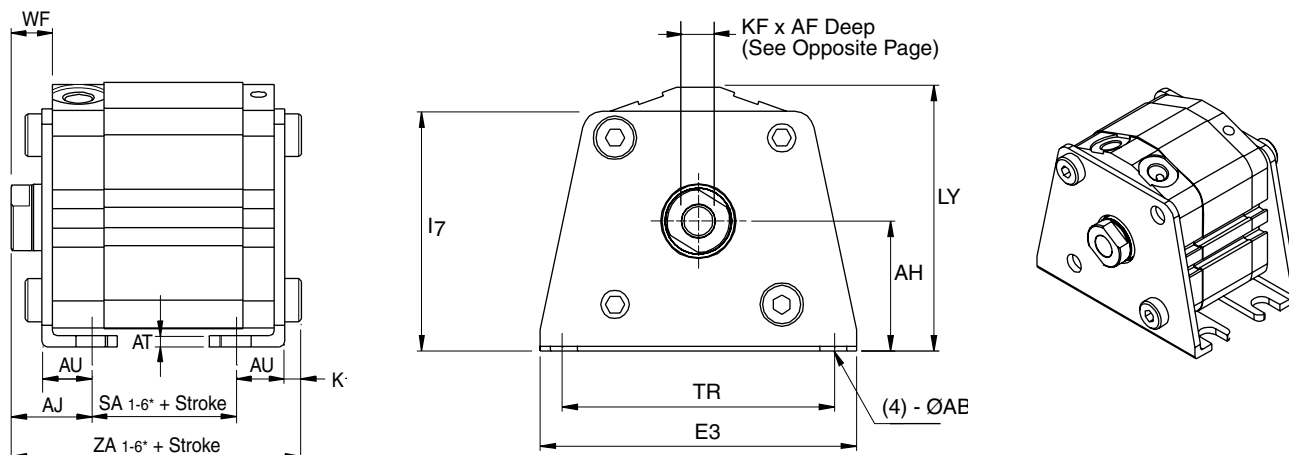

Please note bearing, piston and porting configuration for selecting proper dimensions.

Bore	Kit Part Number	AB	AH	AJ	AT	AU	E ₃	I ₇	K ₁	LY	TR
12	P1M-4DMF	4.5	17	19.5	2	8	44	29.5	2.8	34	35
16	P1M-4FMF	4.5	19	19.5	2	8	48	33.5	2.8	38	39
20	P1M-4HMF	6.5	24	20.5	3.2	9.2	62	42	4	47	50
25	P1M-4JMF	6.5	26	22.5	3.2	10.7	66	46	4	50.5	52
32	P1M-4KMF	6.5	30	25	3.2	11.2	71	54	4	62	60
40	P1M-4LMF	6.5	33	25	3.2	11.2	78	61	4	67.5	67
50	P1M-4MMF	9	39	29.5	3.2	14.7	95	72.5	5	80	82
63	P1M-4NMF	11	46	31	3.2	16.2	113	32	5	91.5	100
80	P1M-4PMF	13	59	35	4.5	19.5	140	42	7	117	118
100	P1M-4QMF	13	71	39	6	23	162	53	7	138	139

Bore	ELP Version Non-Magnetic					ELP Version Magnetic					Long Bearing Version				Style 5 End Length Adjustment	
	Both Ports Head		Optional Porting		Min. ** Stroke	Both Ports Head		Optional Porting		Min.** Stroke	Both Ports Head		Optional Porting			Min.** Stroke
	SA ₁	ZA ₁ *	SA ₂ *	ZA ₂ *		SA ₃	ZA ₃ *	SA ₄	ZA ₄ *		SA ₅	ZA ₅ *	SA ₆	ZA ₆ *		
12	5	35.3	10	40.3	15	16	46.3	21	51.3	4	21.5	51.8	26.5	56.8	4	1.5
16	6.5	36.8	11.5	41.8	14	17.5	47.8	22.5	52.8	4	23.5	53.8	28.5	58.8	4	2
20	7.5	41.2	12	45.7	18	17.5	51.2	22	55.7	8	23.5	57.2	28	61.9	8	2
25	7.5	44.7	13.5	50.7	18	17.5	54.7	23.5	60.7	8	21.5	58.7	27.5	64.7	8	2.5
32	12.5	52.5	20.5	60.7	18	21.5	61.7	29.5	69.9	9	24	64	32	72.2	9	1
40	13.5	53.7	21.5	61.9	17	23.5	63.7	31.5	71.9	7	25.5	65.7	33.5	73.9	7	1
50	9.5	58.7	15.5	64.9	22	18.5	67.7	24.5	73.9	13	20.5	69.7	26.5	75.9	13	-0.5
63	8	60.2	13.5	65.7	30	20	72.2	25.5	77.7	18	23	75.2	28.5	80.7	18	-0.5
80	13	74.5	22	83.5	33	23.5	85	32.5	94	23	23.5	85	32.5	94	23	1
100	14.5	83.5	23	92	33	29	98	37.5	106.5	18	29	98	37.5	106.5	18	-1

* For strokes less than 'Min. Stroke', only one bracket will be supplied at rod end.

** Dimensions shown apply only for Rod End Styles 4, 6 and 9. For Rod End Style 5, please include the above length adjustment.

Note: Foot Bracket mounting is not available with cap face porting

Front Flange Mounting – Style J

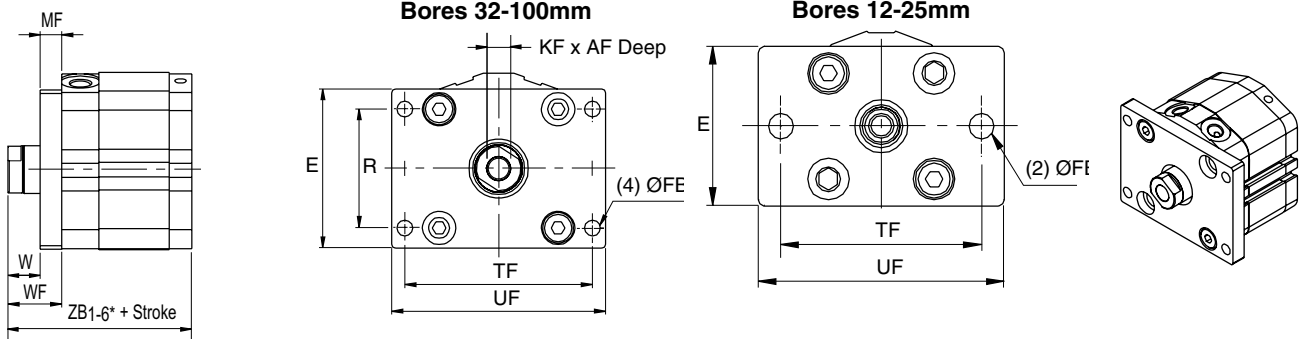

Please note bearing, piston and porting configuration for selecting proper dimensions.

Bore	Kit Part Number	E	FB	MF	R	TF	UF	ELP Version Non-Magnetic		ELP Version Magnetic		Long Bearing Version		Style 5 Rod End Length Adjustment
								Both Ports Head	Optional Porting	Both Ports Head	Optional Porting	Both Ports Head	Optional Porting	
								ZB ₁ *	ZB ₂ *	ZB ₃ *	ZB ₄ *	ZB ₅ *	ZB ₆ *	
12	P1M-4DMB	25	4.5	5.5	–	45	55	30.5	35.5	41.5	46.5	47	52	1.5
16	P1M-4FMB	30	4.5	5.5	–	45	55	32	37	43	48	49	54	2
20	P1M-4HMB	39	6.5	8	–	50.5	62	34	38.5	44	48.5	50	54.5	2
25	P1M-4JMB	42	6.5	8	–	53	65	37.5	43.5	47.5	53.5	51.5	57.5	2.5
32	P1M-4KMB	48	5.5	8	34	58	68	45.5	53.5	54.5	62.5	57	65	1
40	P1M-4LMB	54	5.5	8	40	66	76	46.5	54.5	56.5	64.5	58.5	66.5	1
50	P1M-4MMB	67	6.5	9	50	79	90	50.5	56.5	59.5	65.5	61.5	67.5	-0.5
63	P1M-4NMB	80	9	9	60	97	112	52	57.5	64	69.5	67	72.5	-0.5
80	P1M-4PMB	99	11	11	77	116	134	63	72	73.5	82.5	73.5	82.5	1
100	P1M-4QMB	117	11	11	94	137	154	70.5	79	85	93.5	85	93.5	-1

* Dimensions shown apply only for Rod End Styles 4, 6 and 9. For Rod End Style 5, please include the above length adjustment.

Rod End Dimensions
Front Mounts F & J

For special rod threads, specify "3" in model number and give desired AM or AF, WF and KK or KF.

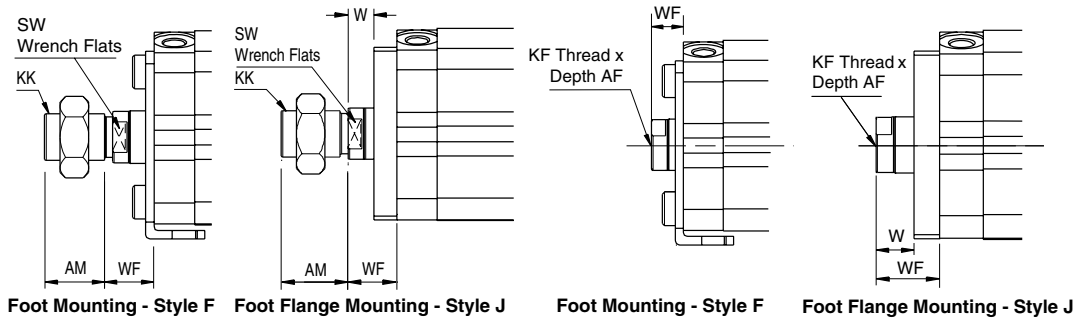

Bore	AF		AM		KF		KK		W		WF		SW
	Style 9	Style 6	Style 4	Style 5	Style 9	Style 6	Style 4	Style 5	Styles 9, 6, 4	Style 5	Styles 9, 6, 4	Style 5	
12	5.4	6	8	9	#8-32	M3X0.5	#8-32	M5X0.8	8	9.5	13.5	15	5
16	5.4	8	8	10	#8-32	M4x0.7	#8-32	M6x1.0	8	10	13.5	15.5	7
20	7	7	8	12	#10-32	M5x0.8	#10-32	M8x1.25	6.5	8.5	14.5	16.5	9
25	10	12	9.5	15	1/4-28	M6x1.0	1/4-28	M10x1.25	7	9.5	15	17.5	9
32	13.3	13	12.7	20.5	5/16-24	M8x1.25	5/16-24	M12x1.25	9	10	17	18	10
40	18.3	13	16	20.5	3/8-24	M8x1.25	3/8-24	M14x1.5	9	10	17	18	13
50	17.6	15	19.5	26	1/2-20	M10x1.5	1/2-20	M18x1.5	9	8.5	18	17.5	16
63	17.6	15	19.5	26	1/2-20	M10x1.5	1/2-20	M18x1.5	9	8.5	18	17.5	16
80	24.3	21	25.5	32.5	5/8-18	M16x2.0	5/8-18	M22x1.5	9	10	20	21	21
100	27	27	28.5	32.5	3/4-16	M20x2.5	3/4-16	M22x1.5	11	10	22	21	21



Rear Flange Mounting – Style H

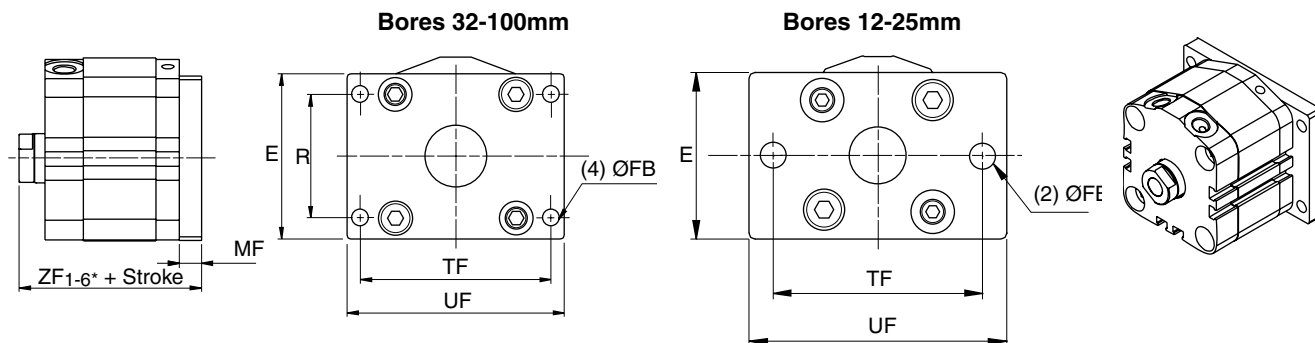

Please note bearing, piston and porting configuration for selecting proper dimensions.

Bore	Kit Part Number	E	FB	MF	R	TF	UF
12	P1M-4DMB	25	4.5	5.5	–	45	55
16	P1M-4FMB	30	4.5	5.5	–	45	55
20	P1M-4HMB	39	6.5	8	–	50.5	62
25	P1M-4JMB	42	6.5	8	–	53	65
32	P1M-4KMB	48	5.5	8	34	58	68
40	P1M-4LMB	54	5.5	8	40	66	76
50	P1M-4MMB	67	6.5	9	50	79	90
63	P1M-4NMB	80	9	9	60	97	112
80	P1M-4PMB	99	11	11	77	116	134
100	P1M-4QMB	117	11	11	94	137	154

Bore	ELP Version Non-Magnetic		ELP Version Magnetic		Long Bearing Version		Style 5 Rod End Length Adjustment
	Both Ports Head ZF ₁ *	Optional Porting ZF ₂ *	Both Ports Head ZF ₃ *	Optional Porting ZF ₄ *	Both Ports Head ZF ₅ *	Optional Porting ZF ₆ *	
12	26	31	37	42	42.5	47.5	1.5
16	27.5	32.5	38.5	43.5	44.5	49.5	2
20	32	36.5	42	46.5	48	52.5	2
25	35.5	41.5	45.5	51.5	49.5	55.5	2.5
32	43.5	51.5	52.5	60.5	55	63	1
40	44.5	52.5	54.5	62.5	56.5	64.5	1
50	49.5	55.5	58.5	64.5	60.5	66.5	-0.5
63	51	57.5	63	68.5	66	71.5	-0.5
80	64	73	74.5	83.5	74.5	83.5	1
100	71.5	80	86	94.5	86	94.5	-1

Note: Rear Flange mounting is not available with cap face porting.

* Dimensions shown apply only for Rod End Styles 4, 6 and 9.

For Rod End Style 5, please include the above length adjustment.

Rear Clevis Mounts – Styles A & B

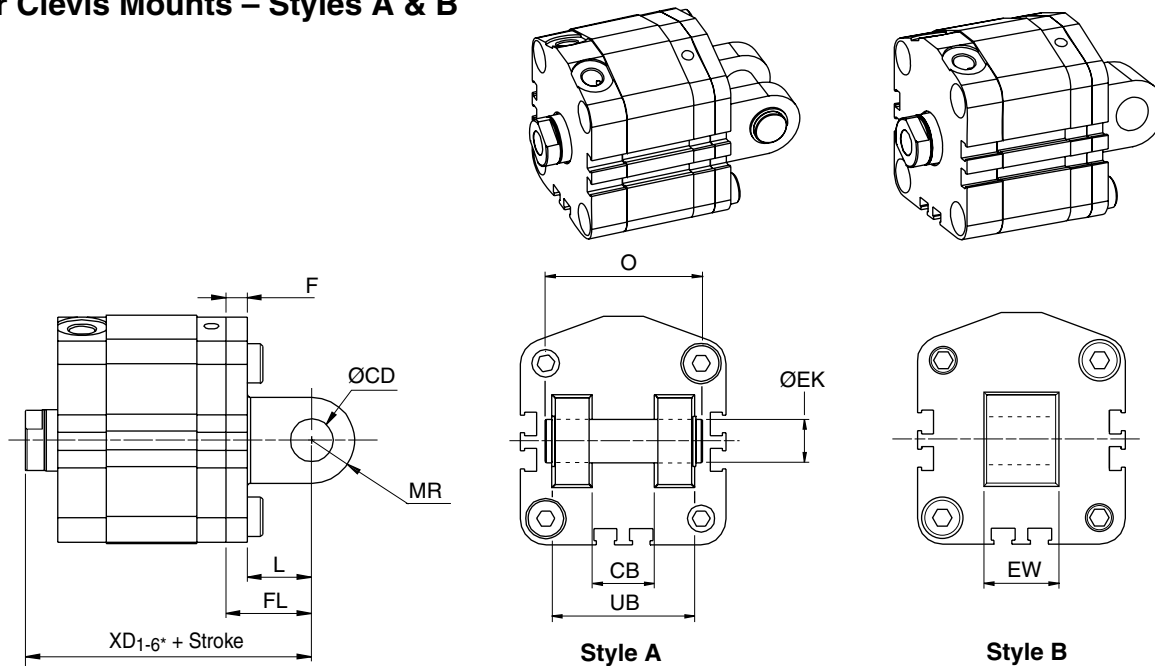

Please note bearing, piston and porting configuration for selecting proper dimensions.

Bore	Double Clevis Kit Part Number	Single Clevis Kit Part Number**	CB	CD/EK	EW	F	FL	L	MR	O	UB
12	P1M-4DMT	P1M-4DME	5	5	5	4	14	10	6.5	14.5	10
16	P1M-4FMT	P1M-4FME	6.5	5	6.5	4	15	11	6.5	16.5	12
20	P1M-4HMT	P1M-4HME	8	8	8	5	18	13	10	21	16
25	P1M-4JMT	P1M-4JME	10	10	10	5	20	15	11	25.5	20
32	P1M-4KMT	P1M-4KME	18	10	18	5	20	15	10	41.5	36
40	P1M-4LMT	P1M-4LME	18	10	18	6	22	16	10	41.5	36
50	P1M-4MMT	P1M-4MME	22	14	22	7	28	21	14	50.5	44
63	P1M-4NMT	P1M-4NME	22	14	22	8	30	22	14	50.5	44
80	P1M-4PMT	P1M-4PME	28	18	28	10	38	28	18	64	56
100	P1M-4QMT	P1M-4QME	32	22	32	13	45	32	22	72	64



Bore	ELP Version Non-Magnetic		ELP Version Magnetic		Long Bearing Version		Style 5 Rod End Length Adjustment
	Both Ports Head XD ₁ *	Optional Porting XD ₂ *	Both Ports Head XD ₃ *	Optional Porting XD ₄ *	Both Ports Head XD ₅ *	Optional Porting XD ₆ *	
12	34.5	39.5	45.5	50.5	51	56	1.5
16	37	42	48	53	54	59	2
20	42	46.5	52	56.5	58	62.5	2
25	47.5	53.5	57.5	63.5	61.5	67.5	2.5
32	55.5	63.5	64.5	72.5	67	75	1
40	58.5	66.5	68.5	76.5	70.5	78.5	1
50	68.5	74.5	77.5	83.5	79.5	85.5	-0.5
63	72	78.5	84	89.5	87	92.5	-0.5
80	91	100	101.5	110.5	101.5	110.5	1
100	105.5	114	120	128.5	120	128.5	-1

* Dimensions shown apply only for Rod End Styles 4, 6 and 9. For Rod End Style 5, please include the above length adjustment.

** Single Clevis Kit can be used as mounting bracket for double clevis cylinders. Double Clevis Kit can be used as mounting kit for single clevis cylinders.

Note: Rear Clevis mounts are not available with cap face port.

Basic Cylinder – Style C
Flange Mounting – Style J

Heads Ported at Each End or One End

Refer to “Single Rod” (pages E6-E9) for dimensions not listed below. Both rods will be supplied with same rod ends unless called out as special.

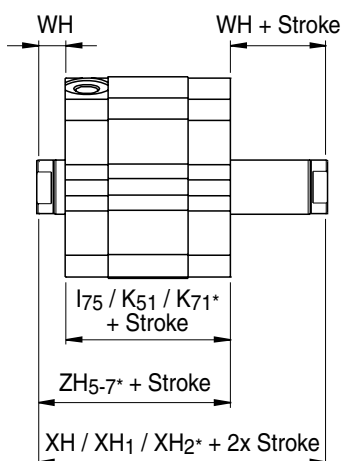

Style C

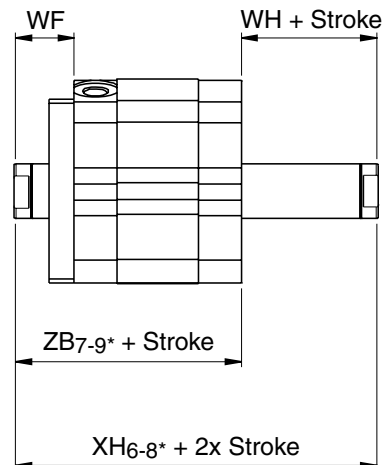

Style J

Please note bearing, piston and porting configuration for selecting proper dimensions.

Bore	Basic Cylinder – Style C											
	ELP Version Non-Magnetic				ELP Version Magnetic				Long Bearing Version			
	K ₅₁	XH ₂	ZH ₇	Min. Stroke	K ₇₁	XH ₁	ZH ₆	Min. Stroke	l ₇₅	XH	ZH ₅	Min. Stroke
12	22	29	25.5	15	40	47	43.5	5	45.5	52.5	49	5
16	23.5	30.5	27	14	40	47	43.5	5	46.5	53.5	50	5
20	24	33	28.5	18	38	47	42.5	8	46.5	55.5	51	8
25	28.5	38.5	33.5	18	38.5	48.5	43.5	8	46.5	56.5	51.5	8
32	36.5	50.5	43.5	18	46	60	53	9	50.5	64.5	57.5	9
40	37.5	51.5	44.5	17	47.5	61.5	54.5	14	51.5	65.5	58.5	12
50	38.5	54.5	46.5	22	47.5	63.5	55.5	20	51.5	67.5	59.5	20
63	39.5	55.5	47.5	30	51.5	67.5	59.5	20	57.5	73.5	65.5	20
80	52	72	62	33	62.5	82.5	72.5	25	62.5	82.5	72.5	25
100	57	81	69	33	71.5	95.5	83.5	25	71.5	95.5	83.5	25

Bore	Flange Mounting – Style J								
	ELP Version Non-Magnetic			ELP Version Magnetic			Long Bearing Version		
	XH ₆	ZB ₇	Min.* Stroke	XH ₇	ZB ₈	Min.* Stroke	XH ₈	ZB ₉	Min.* Stroke
12	39	35.5	5	57	53.5	5	62.5	59	5
16	40.5	37	5	57	53.5	5	63.5	60	5
20	43	38.5	8	57	52.5	8	65.5	61	8
25	48.5	43.5	18	58.5	53.5	8	66.5	61.5	8
32	60.5	53.5	18	70	62.5	9	74.5	67.5	9
40	61.5	54.5	17	71.5	64.5	14	75.5	68.5	12
50	64.5	56.5	22	73.5	65.5	20	77.5	69.5	20
63	65.5	57.5	30	77.5	69.5	20	83.5	75.5	20
80	82	72	33	92.5	82.5	25	92.5	82.5	25
100	91	79	33	105.5	93.5	25	105.5	93.5	25

Rod End Dimensions			
WF		WH	
Styles 4, 6, 9	Style 5	Styles 4, 6, 9	Style 5
13.5	15	3.5	5
13.5	15.5	3.5	5.5
14.5	16.5	4.5	6.5
15	17.5	5	7.5
17	18	7	8
17	18	7	8
18	17.5	8	7.5
18	17.5	8	7.5
20	21	10	11
22	21	12	11

* Note: Please consult factory for cylinders that require shorter than minimum stroke length listed above.



Foot Mounting – Style F

**Heads Ported at Each End
or One End**

Refer to “Single Rod” (pages E6-E9) for dimensions not listed below. Both rods will be supplied with same rod ends unless called out as special.

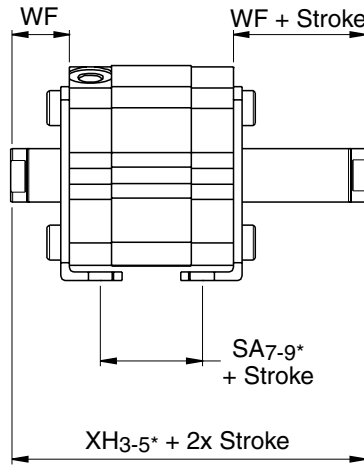

Style F

Please note bearing, piston and porting configuration for selecting proper dimensions.

Bore	ELP Version Non-Magnetic			ELP Version Magnetic			Long Bearing Version		
	SA ₇	XH ₃	Min.* Stroke	SA ₈	XH ₄	Min.* Stroke	SA ₉	XH ₅	Min.* Stroke
12	10	49	5	28	67	5	33.5	72.5	5
16	11.5	50.5	5	28	67	5	34.5	73.5	5
20	12	53	8	26	67	8	34.5	75.5	8
25	13.5	58.5	8	23.5	68.5	5	31.5	76.5	8
32	20.5	70.5	8	29.5	80	5	34.5	84.5	9
40	21.5	71.5	7	31.5	81.5	5	35.5	85.5	12
50	15.5	74.5	12	24.5	83.5	10	28.5	87.5	20
63	13.5	75.5	20	25.5	87.5	10	31.5	93.5	20
80	22	92	23	32.5	102.5	15	32.5	102.5	25
100	23	101	23	37.5	115.5	15	37.5	115.5	25



Bore	Rod End Dimensions			
	WF		WH	
	Styles 4, 6, 9	Style 5	Styles 4, 6, 9	Style 5
12	13.5	15	3.5	5
16	13.5	15.5	3.5	5.5
20	14.5	16.5	4.5	6.5
25	15	17.5	5	7.5
32	17	18	7	8
40	17	18	7	8
50	18	17.5	8	7.5
63	18	17.5	8	7.5
80	20	21	10	11
100	22	21	12	11

* Note: Please consult factory for cylinders that require shorter than minimum stroke length listed above.

Rod Clevis

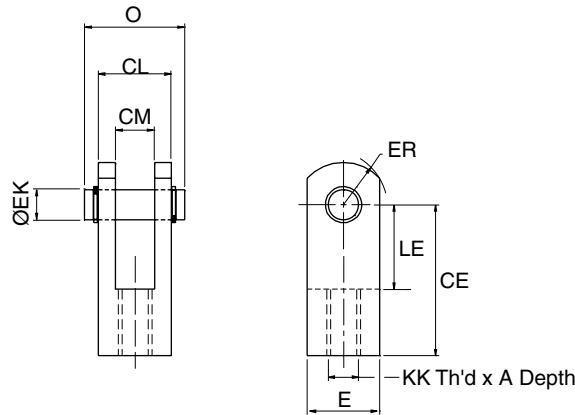

Rod Clevis – Metric

Bore	Kit Part Number	A	E	CE	KK	ER	LE	EK (h9)	CM	CL	O
12	P1M-4DRC	7	9.5	16	M5x0.8	6.5	7	5	5	9.5	14.5
16	P1M-4FRC	11	11	21	M6x1.0	8	10	5	6.5	11	16.5
20	P1M-4HRC	8.5	16	25	M8x1.25	10.5	11.5	8	8	16	21
25	P1M-4JRC	10.5	19	30	M10x1.25	13	14	10	10	19	25.5
32	P1M-4KRC	16	22 Dia.	30	M12x1.25	12	14	10	18	36	41.5
40	P1M-4LRC	16	22 Dia.	30	M14x1.5	12	14	10	18	36	41.5
50/63	P1M-4MRC	20	28 Dia.	40	M18x1.5	16	20	14	22	44	50.5
80	P1M-4PRC	23	38 Dia.	50	M22x1.5	21	27	18	28	56	64
100	P1M-4QRC	24	44 Dia.	55	M22x1.5	24	31	22	32	64	72

Rod Clevis – Inch

Bore	Kit Part Number	A	E	CE	KK	ER	LE	EK (inch) +0, -0.002	CM	CL (inch)	O (inch)
12	P1M-4DRC-T	6	9.5	16	#8-32	6.5	7	3/16	5	0.375	0.563
16	P1M-4FRC-T	6	11	21	#8-32	8	10	3/16	6.5	0.437	0.625
20	P1M-4HRC-T	6	16	25	#10-32	10.5	11.5	5/16	8	0.625	0.875
25	P1M-4JRC-T	8	19	30	1/4-28	13	14	3/8	10	0.750	1.031
32	P1M-4KRC-T	16	22 Dia.	30	5/16-24	12	14	3/8	18	1.437	1.687
40	P1M-4LRC-T	16	22 Dia.	30	3/8-24	12	14	3/8	18	1.437	1.687
50/63	P1M-4MRC-T	20	28 Dia.	40	1/2-20	16	20	1/2	22	1.750	2.125
80	P1M-4PRC-T	23	38 Dia.	50	5/8-18	21	27	3/4	28	2.250	2.625
100	P1M-4QRC-T	24	44 Dia.	55	3/4-16	24	31	7/8	32	2.500	2.875

Jam Nuts

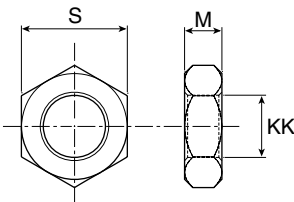

Jam Nut for Style 4

Bore Size	Part Number	KK	M	S
12	L073800080	#8-32	1/8	11/32
16	L073800080	#8-32	1/8	11/32
20	L073800100	#10-32	1/8	3/8
25	L073800200	1/4-28	5/32	7/16
32	L073800300	5/16-24	3/16	1/2
40	L073800400	3/8-24	7/32	9/16
50	L073800600	1/2-20	5/16	3/4
63	L073800600	1/2-20	5/16	3/4
80	L073800800	5/8-18	3/8	15/16
100	L073800900	3/4-16	27/64	1-1/8

Dimensions in inches

Jam Nut for Style 5

Bore Size	Part Number	KK	M	S
12	L075540005	M5x0.8	2.7	18
16	L075540006	M6x1.0	3.2	10
20	L075540008	M8x1.25	4	13
25	L075540010	M10x1.25	5	17
32	L075540012	M12x1.25	6	19
40	L075540014	M14x1.5	7	22
50	L075540018	M18x1.5	8	27
63	L075540018	M18x1.5	8	27
80	L075540022	M22x1.5	11	32
100	L075540022	M22x1.5	11	32

Dimensions in mm

Rod Eye

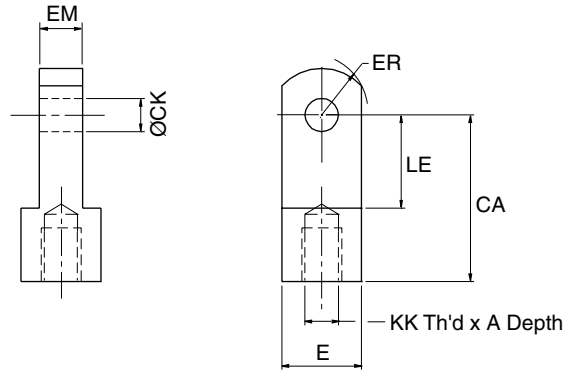

Rod Eye – Metric

Bore	Kit Part Number	A	E	CA	KK	ER	LE	CK	EM
12	P1M-4DRE	7	9.5 Sq.	16	M5x0.8	6.5	7	5	5
16	P1M-4FRE	8	11 Sq.	25	M6x1.0	8	14	5	6.5
20	P1M-4HRE	8.5	16 Sq.	25	M8x1.25	10.5	11.5	8	8
25	P1M-4JRE	10.5	19 Sq.	30	M10x1.25	13	14	10	10
32	P1M-4KRE	15	22 Dia.	30	M12x1.25	12	14	10	18
40	P1M-4LRE	14	22 Dia.	30	M14x1.5	12	14	10	18
50/63	P1M-4MRE	18.5	28 Dia.	40	M18x1.5	16	20	14	22
80	P1M-4PRE	22	38 Dia.	50	M22x1.5	21	27	18	28
100	P1M-4QRE	22	44 Dia.	55	M22x1.5	24	31	22	32



Rod Eye – Inch

Bore	Kit Part Number	A	E	CA	KK	ER	LE	CK (inch)	EM
12	P1M-4DRE-T	6	9.5 Sq.	16	#8-32	6.5	7	3/16	5
16	P1M-4FRE-T	6	11 Sq.	25	#8-32	8	14	3/16	6.5
20	P1M-4HRE-T	6	16 Sq.	25	#10-32	10.5	11.5	5/16	8
25	P1M-4JRE-T	8	19 Sq.	30	1/4-28	13	14	3/8	10
32	P1M-4KRE-T	12	22 Dia.	30	5/16-24	12	14	3/8	18
40	P1M-4LRE-T	11	22 Dia.	30	3/8-24	12	14	3/8	18
50/63	P1M-4MRE-T	18	28 Dia.	40	1/2-20	16	20	1/2	22
80	P1M-4PRE-T	21	38 Dia.	50	5/8-18	21	27	3/4	28
100	P1M-4QRE-T	21	44 Dia.	55	3/4-16	24	31	7/8	32

Bore	Single Rod Cylinders		Double Rod Cylinders	
	Class 1 Seals	Class 5 Seals*	Class 1 Seals	Class 5 Seals*
12	P1M-6DRN	P1M-6DRV	P1M-6DRT	P1M-6DRP
16	P1M-6FRN	P1M-6FRV	P1M-6FRT	P1M-6FRP
20	P1M-6HRN	P1M-6HRV	P1M-6HRT	P1M-6HRP
25	P1M-6JRN	P1M-6JRV	P1M-6JRT	P1M-6JRP
32	P1M-6KRN	P1M-6KRV	P1M-6KRT	P1M-6KRP
40	P1M-6LRN	P1M-6LRV	P1M-6LRT	P1M-6LRP
50	P1M-6MRN	P1M-6MRV	P1M-6MRT	P1M-6MRP
63	P1M-6NRN	P1M-6NRV	P1M-6NRT	P1M-6NRP
80	P1M-6PRN	P1M-6PRV	P1M-6PRT	P1M-6PRP
100	P1M-6QRN	P1M-6QRV	P1M-6QRT	P1M-6QRP

* No Bumpers Included

