



# P1A Series

Mini ISO 6432  
Pneumatic Cylinders



## Section H



Features .....	H2
Ordering Information / Stroke Lengths .....	H3
Technical Data .....	H4-H6
Dimensions .....	H7
Cylinder Mountings .....	H8-H9



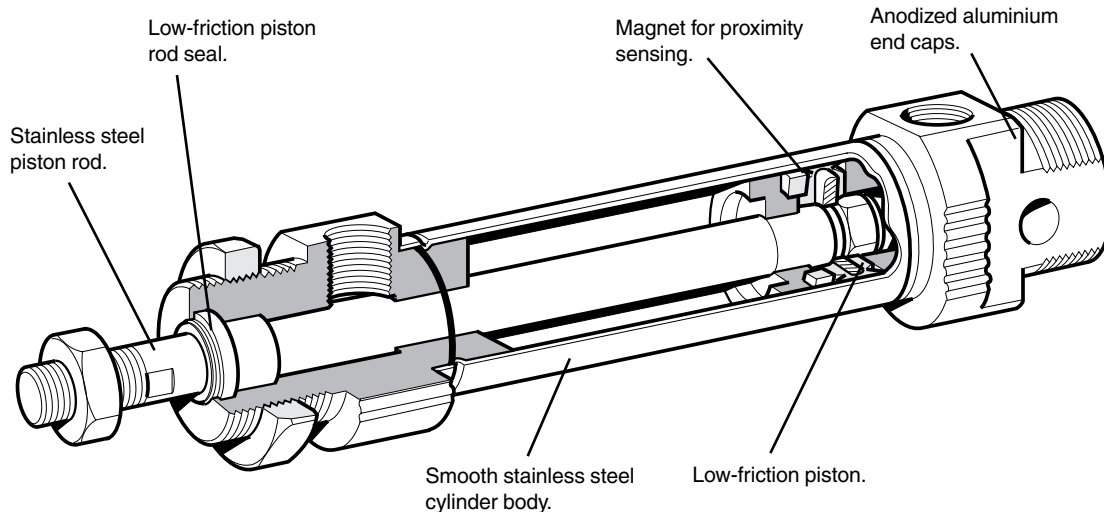

The Parker P1A series of pneumatic cylinders are intended for use in a wide range of applications. These cylinders are particularly suitable for lighter duties in the packaging, food and textile industries. Hygienic design, the use of corrosion-resistant materials and initial lubrication with our food-grade grease makes the cylinders suitable for food industry applications.

Proven design and high quality manufacturing throughout ensure long service life and optimum performance.

Mounting dimensions are in accordance with ISO 6432 and CETOP RP52P. This greatly simplifies installation and worldwide interchangeability.

The Mini ISO range is available with bumpers or adjustable pneumatic cushioning. Controlled by simple bleed screws for fine adjustment, the adjustable cushioned cylinders can be operated with higher mass loads and at higher speeds than those with fixed end cushioning bumpers.

The Mini ISO range is also available in an all-stainless version with piston rod, cylinder body and end covers of stainless steel for use in extremely severe environments. Consult the Actuator Division for more information.

A complete range of sensors for proximity sensing is available as accessories: both reed and solid state sensors are available. Either can be supplied with flying leads or cable and multi-pin connector. See Electronic Sensors section for specifications and part numbers.

### Double Acting

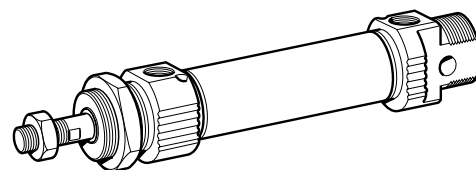

### Double Acting, Double Rod

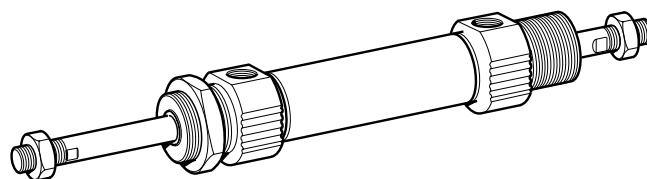

### Single-Acting, Spring Return

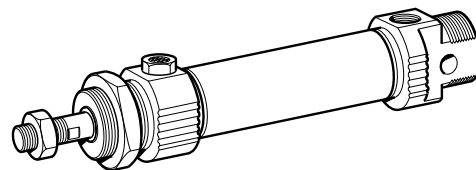

### Single-Acting, Spring Extend

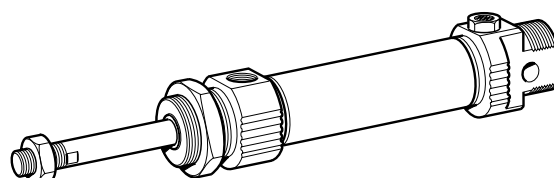

**Order Key**

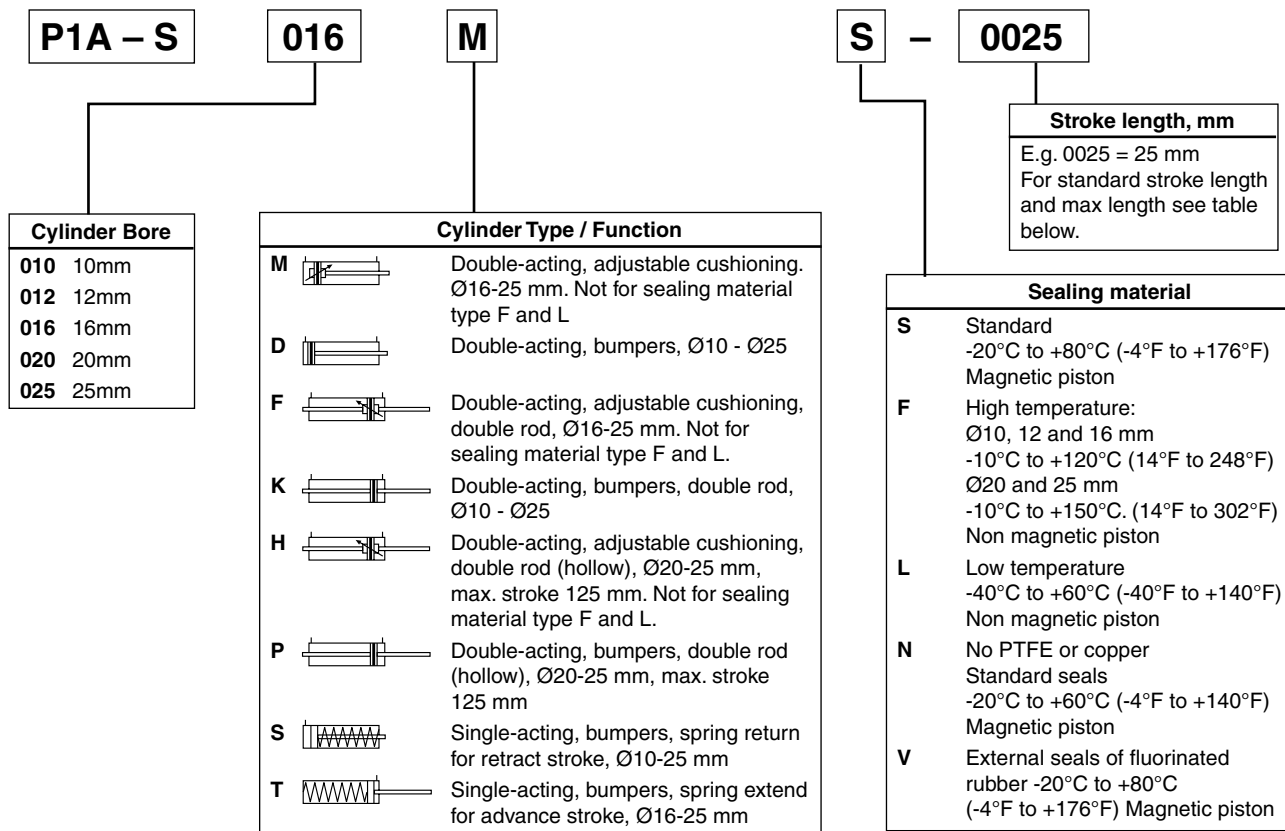

**Stroke Lengths**

Cylinder Model	Bore Size	Stroke Length (● = standard, ● = non-standard, blank = N/A)															
		10	15	20	25*	30	40	50*	80*	100*	125*	160*	200*	250*	320*	400*	500*
<b>Double acting with fixed end-cushioning:</b>																	
P1A-S 010 D	10	●	●	●	●	●	●	●	●	●	●	●	●	●	●	●	●
P1A-S 012 D	12	●	●	●	●	●	●	●	●	●	●	●	●	●	●	●	●
P1A-S 016 D	16	●	●	●	●	●	●	●	●	●	●	●	●	●	●	●	●
P1A-S 020 D	20	●	●	●	●	●	●	●	●	●	●	●	●	●	●	●	●
P1A-S 025 D	25	●	●	●	●	●	●	●	●	●	●	●	●	●	●	●	●
<b>Double acting with adjustable end-cushioning:</b>																	
P1A-S 016 M	16			●	●	●	●	●	●	●	●	●	●	●	●	●	●
P1A-S 020 M	20			●	●	●	●	●	●	●	●	●	●	●	●	●	●
P1A-S 025 M	25			●	●	●	●	●	●	●	●	●	●	●	●	●	●
<b>Single acting:</b>																	
P1A-S 010 SS	10	●	●	●	●	●	●	●	●								
P1A-S 012 SS	12	●	●	●	●	●	●	●	●								
P1A-S 016 SS(TS)	16	●	●	●	●	●	●	●	●**								
P1A-S 020 SS(TS)	20	●	●	●	●	●	●	●	●								
P1A-S 025 SS(TS)	25	●	●	●	●	●	●	●	●								

\*Standard stroke lengths in mm according to ISO 4393

\*\* Not for the TS version

**Note:** For sensor specifications and part numbers, please refer to the Electronic Sensors section.



**Standard Specifications**

Working pressure max	10bar (145 PSI)
Working temperature	max +80°C (176°F)
	min -20°C (4°F)
High-temperature version	max +150°C (Ø20 and 25 mm) 302°F
	+120°C (Ø10, 12 and 16 mm) 248°F
Low-temperature version	min -10°C 14°F
	max +60°C 140°F
	min -40°C -40°F



Prelubricated, further lubrication is not normally necessary.  
 If additional lubrication is introduced it must be continued.

**Material Specification**

Piston rod	Stainless steel, DIN X 10 CrNiS 18 9
Piston rod seal	Fluorocarbon rubber FPM
Piston rod bearing	Multilayer PTFE/steel
End covers	Anodized aluminium
O-ring, internal	Nitrile rubber, NBR
Cylinder barrel	Stainless steel, DIN X 5 CrNi 18 10
Piston, complete	Nitrile rubber, NBR/steel
Magnet holder	Thermoplastic elastomer
Magnet	Plastic-coated magnetic material
Return spring	Surface-treated steel
Cushioning screw	Stainless steel, DIN X 10 CrNiS 18 9

**Variants Mini ISO:**

**Low-temperature version, type L:**

Piston rod seal	Nitrile rubber, NBR
Piston complete	Nitrile rubber, NBR/steel

**High-temperature version, type F:**

Piston rod seal	Fluorocarbon rubber, FPM
Piston complete, Ø10-Ø16	HNBR/steel
Piston complete, Ø20-Ø25	FPM/steel

**PTFE and copper free cylinders, type N:**

Piston rod bearing	PA plastic
--------------------	------------

**Cylinders with outer sealings in fluorocarbon, type V:**

Piston rod seal/	
Scraper ring	Fluorocarbon rubber, FPM

**Note:** Spare part = new cylinder

Cylinders are supplied complete with nose mounting and piston rod nuts.  
 Cylinders with double piston rods are supplied with two piston rod nuts

**Quick Reference**

Model #	Cylinder		Piston Rod		Thread	Total Weight at 0mm Stroke (lbs)	Additional Weight per 10mm Stroke (lbs)	Air Consumption	Port Size
	Bore (mm)	Area (cm <sup>2</sup> )	Dia. (mm)	Area (cm <sup>2</sup> )					
<b>Double acting, cushioned stroke</b>									
P1A-S 010 D	10	0.78	4	0.13	M4	0.09	0.007	0.0004 <sup>1)</sup>	M5
P1A-S 012 D	12	1.13	6	0.28	M6	0.15	0.009	0.0005 <sup>1)</sup>	M5
P1A-S 016 D	16	2.01	6	0.28	M6	0.20	0.012	0.0009 <sup>1)</sup>	M5
P1A-S 020 D	20	3.14	8	0.50	M8	0.40	0.015	0.0010 <sup>1)</sup>	G1/8
P1A-S 025 D	25	4.91	10	0.78	M10x1.25	0.89	0.025	0.0023 <sup>1)</sup>	G1/8
<b>Double acting, adjustable cushioning</b>									
P1A-S 016 M	16	2.01	6	0.28	M6	0.20	0.012	0.0009 <sup>1)</sup>	M5
P1A-S 020 M	20	3.14	8	0.50	M8	0.40	0.015	0.0010 <sup>1)</sup>	G1/8
P1A-S 025 M	25	4.91	10	0.78	M10x1.25	0.89	0.025	0.0023 <sup>1)</sup>	G1/8
<b>Single acting</b>									
P1A-S 010 SS	10	0.78	4	0.13	M4	0.09	0.007	0.0002 <sup>1)</sup>	M5
P1A-S 012 SS	12	1.13	6	0.28	M6	0.18	0.009	0.0003 <sup>1)</sup>	M5
P1A-S 016 SS(TS)	16	2.01	6	0.28	M6	0.22	0.012	0.0005 <sup>1)</sup>	M5
P1A-S 020 SS(TS)	20	3.14	8	0.50	M8	0.40	0.015	0.0008 <sup>1)</sup>	G1/8
P1A-S 025 SS(TS)	25	4.91	10	0.78	M10x1.25	0.58	0.025	0.0013 <sup>1)</sup>	G1/8

1) Free air consumption per 10 mm stroke length for a double stroke at 6 bar (87 PSI)

### Cylinder Forces

Indicated cylinder forces are theoretical and should be reduced according to the working conditions.

#### Double Acting

Model Number	Bore Size mm	Theoretical Piston Force (lbs) at 6 Bar (87 PSI)	
		Extension	Retraction
P1A-S 010 D	10	10.57	8.76
P1A-S 012 D	12	15.07	11.25
P1A-S 016 D	16	26.98	23.15
P1A-S 020 D	20	42.27	35.52
P1A-S 025 D	25	66.10	55.53
P1A-S 016 M	16	26.98	23.16
P1A-S 020 M	20	42.27	35.52
P1A-S 025 M	25	66.10	55.53

#### Single Acting

Model Number	Stroke	Theoretical Piston Force (lbs) at 6 Bar (87 PSI)			
		Spring Retraction		Spring Extension	
		lbs max	lbs. min	lbs. max	lbs. min
P1A-S 010 SS	10	8.5	8.1	2.4	2.0
	15	8.5	8.1	2.4	2.0
	25	8.7	8.1	2.4	2.0
	40	8.5	7.6	2.9	2.0
	50	8.7	7.6	2.9	1.7
	80	8.7	7.6	2.9	1.7
P1A-S 012 SS	10	11.9	11.4	3.6	3.1
	15	11.9	11.4	3.6	3.1
	25	12.3	11.4	3.6	2.7
	40	11.9	10.8	4.2	3.3
	50	11.9	10.8	4.2	3.1
	80	12.3	10.8	4.2	2.7
P1A-S 016 SS(TS)	10	22.0 (19.1)	22.2 (18.8)	4.7 (4.2)	4.0 (4.0)
	15	23.1 (19.3)	22.2 (18.8)	4.7 (4.2)	3.8 (3.8)
	25	23.8 (19.8)	22.2 (18.8)	4.7 (4.2)	3.3 (3.3)
	40	23.8 (20.3)	21.3 (18.8)	5.6 (4.2)	3.1 (3.1)
	50	24.2 (20.4)	21.3 (18.8)	5.6 (4.2)	2.7 (2.7)
	80	24.0 (21.3)	21.3 (18.8)	5.6 (4.2)	2.9 (2.9)
P1A-S 020 SS(TS)	10	36.6 (29.6)	36.1 (29.2)	6.1 (6.3)	5.6 (5.8)
	15	36.8 (29.8)	36.1 (29.2)	6.1 (6.3)	5.4 (5.6)
	25	37.5 (30.3)	36.1 (29.2)	6.1 (6.3)	4.7 (5.1)
	40	37.3 (31.0)	35.7 (29.2)	6.5 (6.3)	4.9 (4.9)
	50	37.7 (31.4)	35.7 (29.2)	6.5 (6.3)	4.5 (4.5)
	80	38.2 (31.2)	36.1 (24.2)	6.1 (11.2)	4.0 (4.2)
P1A-S 025 SS(TS)	10	57.5 (46.1)	56.9 (45.6)	9.2 (9.9)	8.5 (9.4)
	15	58.0 (46.5)	56.9 (45.6)	9.2 (9.9)	8.1 (9.0)
	25	58.9 (47.2)	56.9 (45.6)	9.2 (9.9)	7.2 (8.3)
	40	58.7 (48.1)	56.2 (45.6)	9.9 (9.9)	7.4 (7.4)
	50	59.4 (48.8)	56.2 (45.6)	9.9 (9.9)	6.7 (6.7)
	80	59.4 (50.1)	56.4 (46.3)	9.6 (9.2)	6.7 (5.4)



**Cushioning**

Use the diagram below to determine the necessary size of cylinder to provide the requisite cushioning performance. The maximum cushioning performance, as indicated in the diagram, is based on the following assumptions:

- Low load, i.e. low pressure drop across the piston
- Steady-state piston speed
- Correctly adjusted cushioning screw

The load is the sum of the internal and external friction, together with any gravity forces. At high relative loading it is recommended that, for a given speed, the load should be reduced by a factor of 2.5, or that, for a given mass, the speed should be reduced by a factor of 1.5. These factors apply in relation to the maximum performance as shown in the diagram.

**Double-acting cushioned cylinders**

Adjustable pneumatic cushioning permits greater loads and higher operating speeds, making the cylinders suitable for more demanding applications.

These cylinders are available in bores of 16, 20 and 25 mm, with stroke lengths from 20 mm to 500 mm.

**Fixed End-Cushioning (Bumpers)**

Speed Ft./Sec.

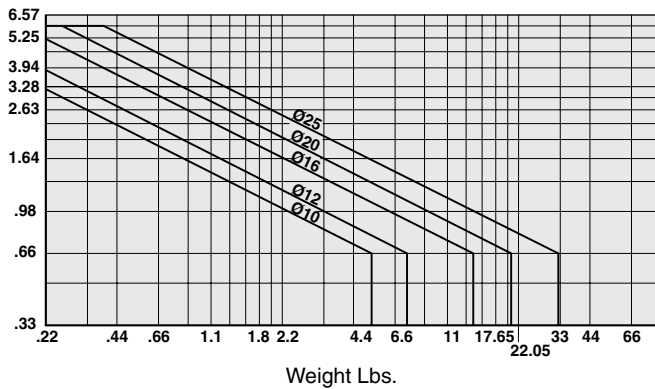

**Adjustable Pneumatic End-Cushioning**

Speed Ft./Sec.

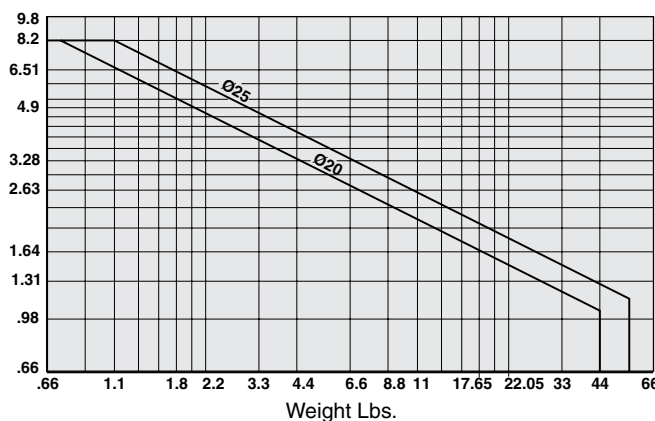

**Double acting cylinders**

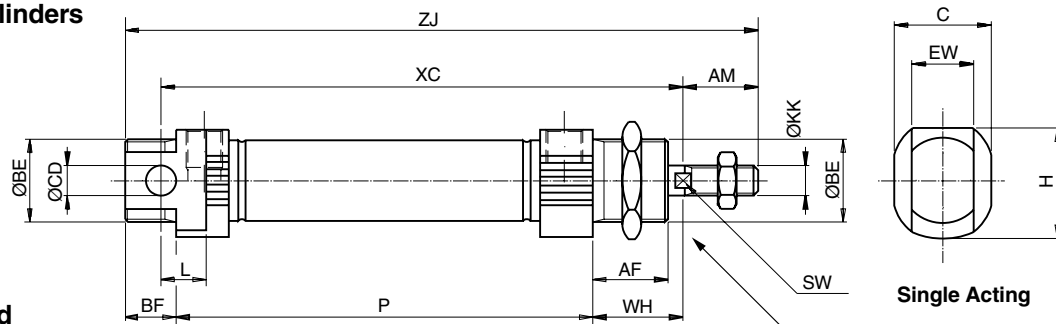

**Double piston rod**

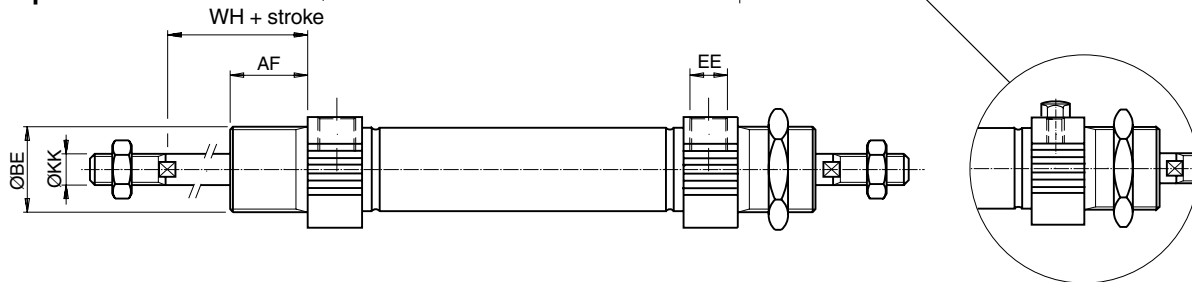

Cylinder bore mm	AM 0/-2 mm	BE	AF mm	BF mm	C mm	CD h9 mm	EE	EW mm	H mm	KK	L mm	SW mm	WH±1.2 mm
10	12	M12x1.25	12	10	14.0	4	M5	8	16.7	M4	6	—	16
12	16	M16x1.5	18	13	18.0	6	M5	12	19.1	M6	9	5	22
16 <sup>1)</sup>	16	M16x1.5	18	13	18.0	6	M5	12	19.1	M6	9	5	22
16 <sup>2)</sup>	16	M16x1.5	18	13	25.0	6	M5	12	24.0	M6	9	5	22
20	20	M22x1.5	20	14	24.0	8	G1/8	16	27.0	M8	12	7	24
25	22	M22x1.5	22	14	27.5	8	G1/8	16	29.0	M10x1.25	12	9	28

1) P1A-S016DS/SS/TS

2) P1A-S016MS

**Double acting cylinders**

Cylinder bore mm	XC mm	ZJ mm	P mm
10	64 + stroke	84 + stroke	46 + stroke
12	75 + stroke	99 + stroke	48 + stroke
16	82 + stroke	104 + stroke	53 + stroke
20	95 + stroke	125 + stroke	67 + stroke
25	104 + stroke	132 + stroke	68 + stroke

**Single-acting, spring return, type SS**

Cylinder Bore mm	XC (mm) at Various Strokes						ZJ (mm) at Various Strokes						P (mm) at Various Strokes					
	10	15	25	40	50	80	10	15	25	40	50	80	10	15	25	40	50	80
10	74	79	89	126	136	174	94	99	109	146	156	194	56	61	71	108	118	156
12	85	90	100	132	142	185	109	114	124	156	166	209	58	63	73	105	115	158
16	92	97	107	122	132	184	114	119	129	144	154	206	63	68	78	93	103	155
20	105	110	120	135	145	191	135	140	150	165	175	221	77	82	92	107	117	163
25	114	119	129	144	154	201	142	147	157	172	182	229	78	83	93	108	118	165

**Single-acting, spring-extended, type TS**

Cylinder Bore mm	ZC <sup>3)</sup> (mm) at Various Strokes						ZJ <sup>3)</sup> (mm) at Various Strokes						P (mm) at Various Strokes					
	10	15	25	40	50	80	10	15	25	40	50	80	10	15	25	40	50	80
16	107	112	122	137	147	—	134	139	149	164	174	—	78	83	93	108	118	—
20	120	125	135	150	160	195	156	161	171	186	196	231	92	97	107	122	132	167
25	129	134	144	159	169	205	165	170	180	195	205	241	93	98	108	123	133	169

3) With piston rod retracted, as shown in the dimension drawing

Length tolerances ±1 mm Stroke length tolerance +1.5/0 mm

**Flange - MF8**

Intended for fixed attachment of the cylinder. The flange is designed for mounting on the front or rear end-covers.

Material: Surface-treated steel

This mounting is also available in stainless steel.

Consult the Actuator Division for additional information.

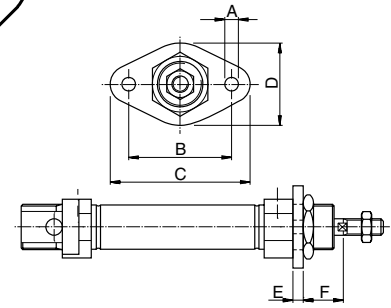
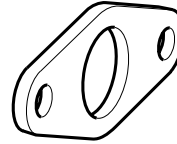

Part Number	Cylinder Ø mm	A	B	C	D	E	F	Weight lbs
P1A-4CMB	10	4.5	30	40	22	3	13	0.025
P1A-4DMB	12-16	5.5	40	52	30	4	18	0.055
P1A-4HMB	20	6.6	50	66	40	5	19	0.100
	25	6.6	50	66	40	5	23	0.100

**Foot - MS3**

Intended for fixed attachment of the cylinder. The bracket is designed for mounting on the front or rear end-covers.

Material: Surface-treated steel

This mounting is also available in stainless steel.

Consult the Actuator Division for additional information.

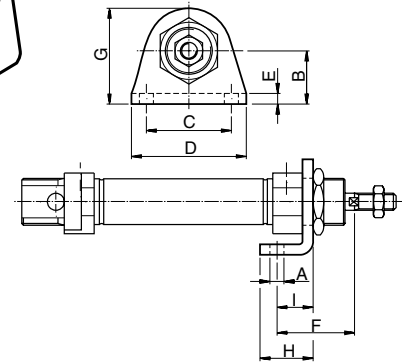
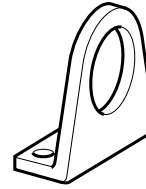

Part Number	Cylinder Ø mm	A mm	B mm	C mm	D mm	E mm	F mm	G mm	H mm	I mm	Weight lbs
P1A-4CMF	10	4.5	16	25	35	3	24	26.0	16	11	0.045
P1A-4DMF	12-16	5.5	20	32	42	4	32	32.5	20	14	0.08
P1A-4HMF	20	6.5	25	40	54	5	36	45.0	25	17	0.18
	25	6.5	25	40	54	5	40	45.0	25	17	0.18



**Cover Trunnion**

Intended for articulated mounting of the cylinder. The flange is designed for mounting on the front or rear end-covers.

Material: Stainless steel, DIN X 10 CrNiS 18 9

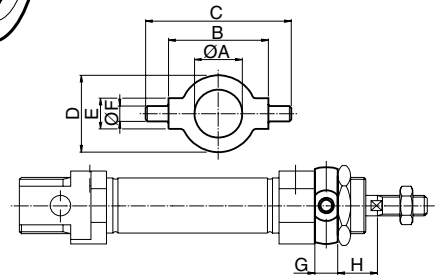
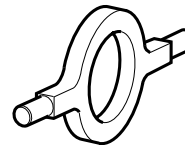

Part Number	Cylinder Ø mm	A mm	B h14 mm	C mm	D mm	E e9 mm	F mm	G mm	H mm	Weight lbs
P1A-4CMJ	10	12.5	26	38	20	8	4	6	10	0.03
P1A-4DMJ	12-16	16.5	38	58	25	10	6	8	14	0.07
P1A-4HMJ	20	22.5	46	66	30	10	6	8	16	0.08
	25	22.5	46	66	30	10	6	8	20	0.08

**Mounting Nut**

Intended for fixed mounting of the cylinder.

Cylinders are supplied complete with one mounting nut.

Material: Galvanized steel

This nut is also available in stainless steel.

Consult Actuator Division for further information.

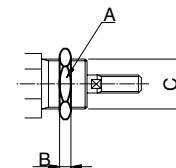
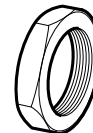

Part Number	Cylinder Ø mm	A mm	B mm	C mm	Weight lbs
9127385101	10	16	3	M12x1.25	0.02
9127385102	12-16	20	4	M16x1.50	0.04
9127385103	20-25	27	5	M22x1.50	0.09



**Clevis Bracket**

Intended for articulated mounting of the cylinder. Supplied with shaft for mounting on the rear end cover.

Material:

- Bracket: surface-treated steel, black
- Pin: surface hardened steel
- Circlips: according to DIN 471: Stainless steel

This mounting is also available in stainless steel. Consult the Actuator Division for additional information.

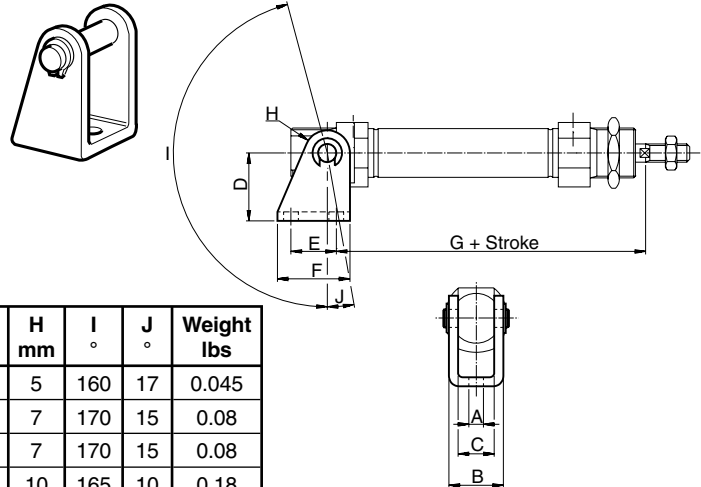

Part Number	Cylinder Ø mm	A mm	B mm	C mm	D mm	E mm	F mm	G mm	H mm	I °	J °	Weight lbs
P1A-4CMT	10	4.5	13	8	24	12.5	20	65.3	5	160	17	0.045
P1A-4DMT	12	5.5	18	12	27	15.0	25	73.0	7	170	15	0.08
	16	5.5	18	12	27	15.0	25	80.0	7	170	15	0.08
P1A-4HMT	20	6.5	24	16	30	20.0	32	91.0	10	165	10	0.18
	25	6.5	24	16	30	20.0	32	100.0	10	165	10	0.18

**Clevis**

According to ISO 8140. Intended for articulated mounting of the cylinder. This mounting is adjustable in the axial direction. Supplied complete with pin.

Material: Galvanized steel

This mounting is also available in stainless steel.

Consult the Actuator Division for additional information.

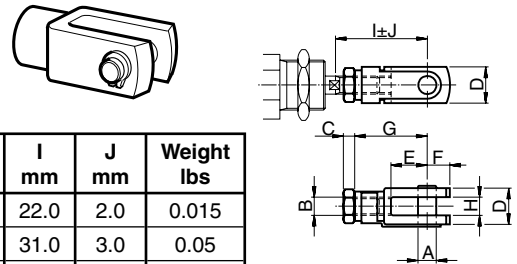

Part Number	Cylinder Ø mm	A mm	B	C mm	D mm	E mm	F mm	G mm	H mm	I mm	J mm	Weight lbs
P1A-4CRC	10	4	M4	2.2	8	8	5	16	4	22.0	2.0	0.015
P1A-4DRC	12-16	6	M6	3.2	12	12	7	24	6	31.0	3.0	0.05
P1A-4HRC	20	8	M8	4.0	16	16	10	32	8	40.5	3.5	0.10
P1A-4JRC	25	10	M10x1.25	5.0	20	20	12	40	10	49.0	3.0	0.21

**Swivel Rod Eye**

According to ISO 8139. Intended for articulated mounting of the cylinder. This mounting is adjustable in the axial direction.

Material:

- Swivel rod eye: Galvanized steel
- Ball: hardened steel

This mounting is also available in stainless steel.

Consult the Actuator Division for additional information.

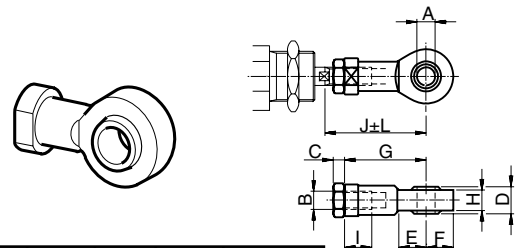

Part Number	Cylinder Ø mm	A mm	B	C mm	D mm	E mm	F mm	G mm	H mm	I mm	J mm	K mm	L mm	Weight lbs
P1A-4CRS	10	5	M4	2.2	8	10	9	27	6.0	8	33.0	9	2.0	0.04
P1A-4DRS	12-16	6	M6	3.2	9	10	10	30	6.8	9	38.5	11	1.5	0.06
P1A-4HRS	20	8	M8	4.0	12	12	12	36	9.0	12	46.0	14	2.0	0.10
P1A-4JRS	25	10	M10x1.25	5.0	14	14	14	43	10.5	15	52.5	17	2.5	0.19

**Rod Nut**

Intended for fixed mounting on the piston rod. Cylinders are supplied complete with one rod nut. (cylinders with double piston rod are supplied with two rod nuts.)

Material: Galvanized steel

This nut is also available in stainless steel. Consult the Actuator Division for additional information.

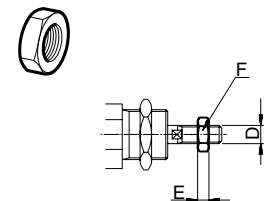

Part Number	Cylinder Ø mm	D mm	F mm	E mm	Weight lbs
0261110600	10	M4	7	2.2	0.002
0261210800	12-16	M6	10	3.2	0.004
0261211000	20	M8	13	4.0	0.010
9128985601	25	M10x1.25	17	5.0	0.015