

NEW!

**Complete Guide
to Options and
Accessories**

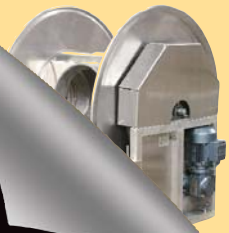

Pre-Conditioned Air Duct Reels



Photo taken at Heathrow, International Airport in London, England



Wind Things Up With Reelcraft™

Reelcraft Industries is
ISO 9001:2000
Certified Since 1996

reelcraft.com

Preconditioned Air (PCA) Reels

Nordic Series 6800 - 14" I.D.

NEW!

Reelcraft's PCA reels handle 75' of 14" I.D. preconditioned air ducting and are designed for ergonomic handling of air ducting in airport ground support applications. When properly installed, Reelcraft's PCA reels supply continuous clean preconditioned air to stationed aircraft. Aluminum construction provides superior corrosion resistance at a fraction of the weight. Reelcraft's PCA reels also offer numerous ergonomic options such as a standard clutch and 360° swivel base.

- Essential component for the transfer and dispensing of preconditioned air
- Meets international PCA ducting requirements for the new A-380 Airbus
- Keeps expensive PCA ducting protected and improves safety on the tarmac
- Motorized retraction is standard
- Aluminum construction prevents corrosion in all weather conditions
- PCA reels are sold without ducting
- Controls not included with powered units

Motor Drive Options

Choose from 50hz, 230/400 volt AC motor or 60hz, 240/480 volt AC motor.

*Adjustable friction clutch is standard

Chain Guard

Chain guards are standard on all models. They promote safety and protect internal working parts.

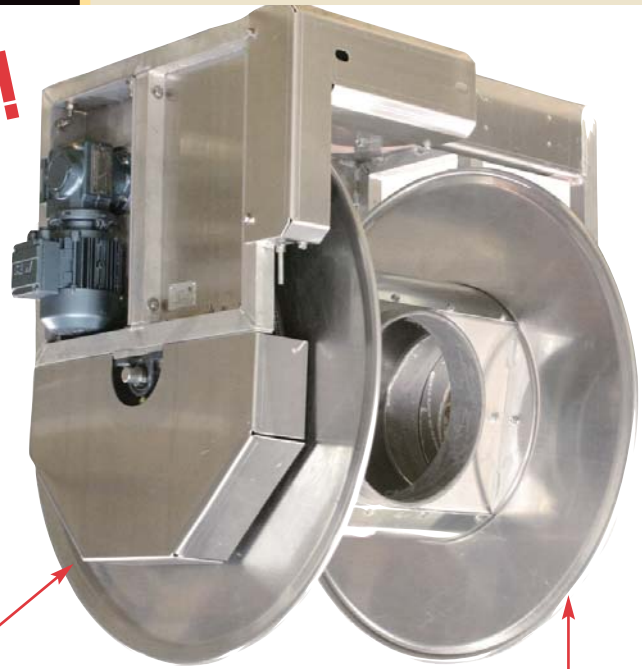

Heavy Duty Sprocket

Painted steel sprocket is designed for heavy industrial applications.

Oversized Rolled Edge

1/2" rolled edge prevents expensive ducting from being damaged during normal, everyday use.

Construction

Welded aluminum tubular frame construction and zinc-plated fasteners ensure the reel maintains its structural integrity through heavy use.

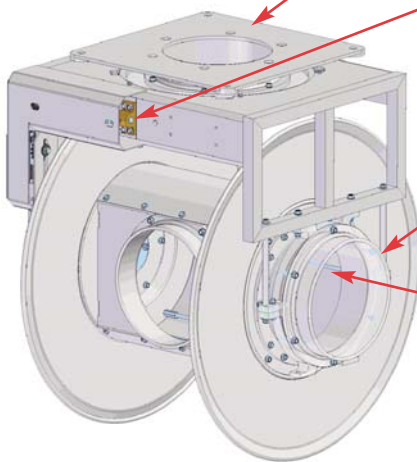

Swivel Base Option

The swivel base option offers 360° of rotation. Consult manufacturer for predesignated limit stops.

Optional Brake Assembly

Terminates spool rotation at complete retraction and payout. End stops are easily adjustable and require few tools.

Flow Path

All joints are sealed for maximum air transfer and minimum loss. Special low friction, self-lubricating 14" bearing enables hose to be removed manually and requires minimum maintenance.

Unitized Tie-Rod Design

Zinc-plated steel tie-rods span from flange to flange to offer superior structural support and ensure the reel does not flex under heavy industrial use.



Reelcraft's pre-conditioned air (PCA) reels, mounted on a free spinning swivel base, are installed inverted on airport boarding bridges for the purpose of cooling and/or heating airplane passenger cabins. These manual or powered rewind reels are available with solid or spoked heads. Powered reels are complete with proximity switches and mechanical stop.

*Model depicted:
EC6850-39-24-14LHI-SFK

North America: **800-444-3134**

Europe: **+44 (0) 1536 406999**

Asia: **+63 (45) 625-6624**

Latin America: **260-489-1685**

reelcraft.com

Reelcraft Industries is

ISO 9001:2000

Certified Since 1996

Pre-Conditioned Air Duct Reels Nordic Series 6800

Model Number Significance

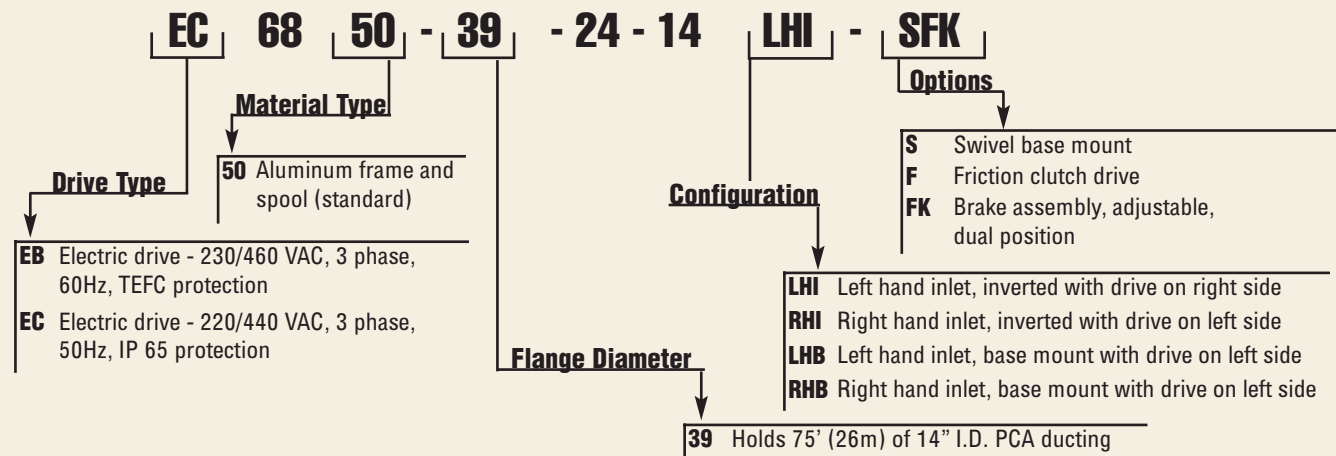

Reel Dimensions

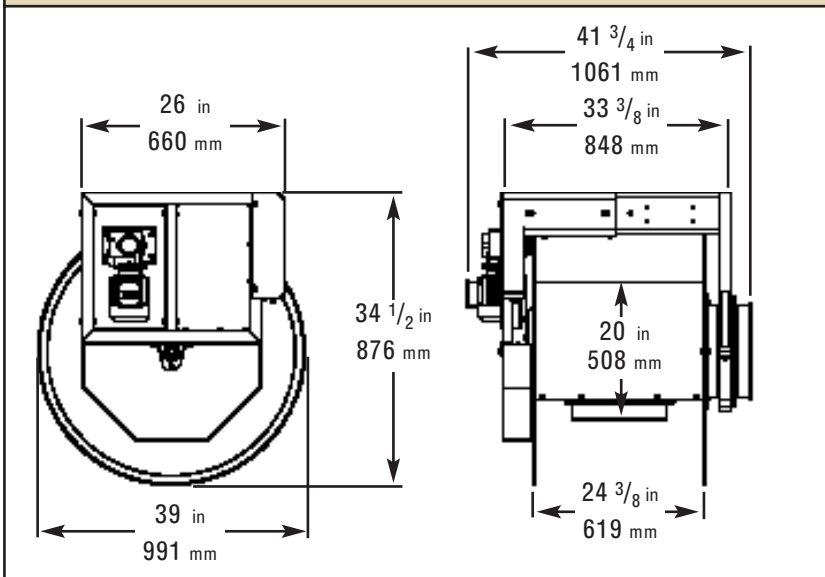

NOTE: For models with optional swivel base assembly add 2 3/8" (61 mm) to "G" dimension. For models with FK brake assembly option add 3 5/8" (92mm) to "D" dimension. It is strongly recommended to consult manufacturer prior to ordering.

Mounting Dimensions (Side view)

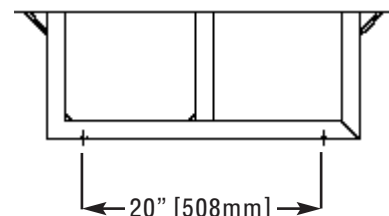

Mounting Dimensions (Front view)

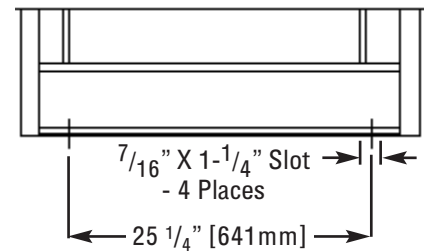

Mounting Dimensions

(Models with swivel base - Option S)

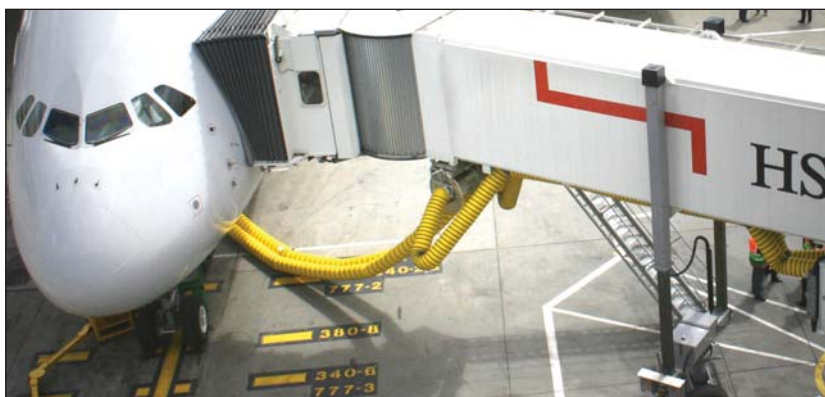
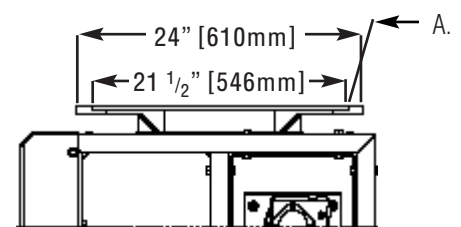

Photo taken at Heathrow, International Airport in London, England

North America: 800-444-3134

Europe: +44 (0) 1536 406999

reelcraft.com

Asia: +63 (45) 625-6624

Latin America: 260-489-1685

REELCRAFT

Wind Things Up With Reelcraft™



Nordic Series
**Hydrant and Above
Ground Refueling
Reels**

Work Smarter

North America Corporate Headquarters

One Reelcraft Center • P.O. Box 248
Columbia City, IN 46725-0248
Ph: 800-444-3134 • Fax: 800-444-4587
Ph: 260-248-8188 • Fax: 260-248-2605
e-mail: reelcraft@reelcraft.com
www.reelcraft.com

Asia Pacific

P.O. Box 53776
Clark Freeport Zone
Philippines 2023
Ph: +63 (45) 625-6624
Fax: +63 (45) 321-0643
e-mail: rap@comclark.com
www.reelcraft.com/asia

Latin America and the Middle East

Thompson International, Inc.
P.O. Box 12958
Ft. Wayne, IN 46866
Ph: 260-489-1685
Fax: 260-489-0203
e-mail: info@t-i-i.com
www.reelcraft.com/latinamerica

Europe

Unit 17 • Cronin Courtyard
Weldon South Industrial Estate
Corby • Northamptonshire • NN18 8AG
United Kingdom
Ph: +44 (0) 1536 406999
Fax: +44 (0) 1536 406777
e-mail: europe@reelcraft.com
www.reelcraft.com/europe

Canada

1705 Argentia Rd. Unit #7
Mississauga, ON L5N 3A9
Ph: 800-444-3134 • Fax: 800-444-4587
e-mail: reelcraft@reelcraft.com

Australia

PO Box 6463 BC, Blacktown
NSW 2148, Australia
Ph: +61 (2) 9621 8988
Fax: +61 (2) 9621 7688
e-mail: sales@recoil.com

China

Reelcraft Changzhou Co., Ltd.
Building C, No. 229 HeHai West Road
Changzhou, Jiangsu, China 213022
Ph: (519) 8512 2391 ext. 8002
Fax: (519) 8512 9309
email: rco@reelcraftchina.com
www.reelcraft.com/china



△ 917-1097



△ MCAT-001

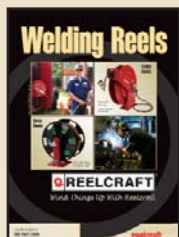

△ 735-1194



△ 1123-802

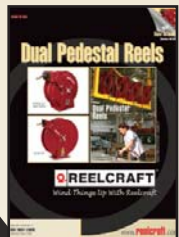

△ DP-407

Form # **PCA-0708** 0804



Wind Things Up With Reelcraft™

reelcraft.com

Reelcraft Industries is
ISO 9001:2000
Certified Since 1996