

# Firefighting Reels

Fire Booster Hose Reels

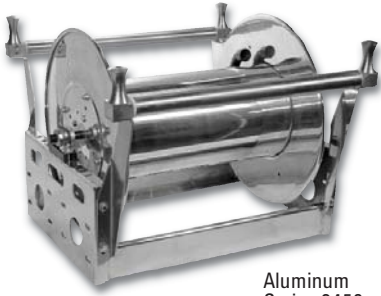

Aluminum  
Series 2450



Photo courtesy of 1st Attack Engineering, Auburn, IN

Firefighting Hose Reels



Series 2400

reelcraft.com



# Custom Built Reels

Reelcraft's engineered products group has the capabilities to custom build to your specifications. Our special engineered products are developed for demanding applications in areas such as marine, military, aviation, hydroseeding, sewer and well cleaning, offshore

oil rigs, robotic cable and much more. We offer flexibility, competitive pricing and a lasting commitment to excellence. For more than 20 years, Reelcraft's engineered products group has produced custom products to meet individualized requirements.



Custom built military grade large frame reels  
 Photo courtesy of Beta Fluid Systems / A Division of Liquip International

## Reelcraft's Capabilities

- Few size and weight constraints**  
We build to meet any extreme size and weight constraints.
- Special finishes/paint options**  
Options include galvanized, CARC paint, marine grade epoxy, liquid enamel coat paint and powder coat paint in any color.
- Various drive types**  
Manual crank, motorized, spring drive, hand-over-hand and more.
- Wide range of pressures**  
A wide variety of pressure ranges available from 50 to 15,000 PSI and beyond.
- Unique options**  
Hose Boss rewind assist, tensioning bars, multiple fluid paths, level rewinds and much more.
- No minimum quantities**  
Order from 1 to as many as you need.



**Firefighting Hose Reels** ▲  
 Custom engineered and built Series 2400 electric motor rewind hose reel.

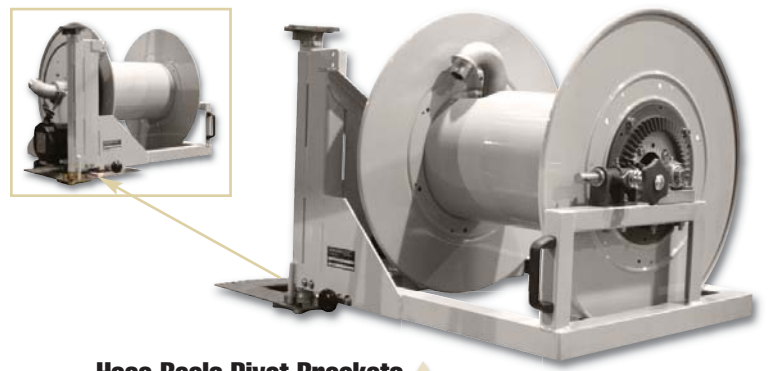

**Hose Reels Pivot Brackets** ▲  
 Bracket is attached to the side of the reel frame. The reel pivots on the bracket with positive stops at 0°, 45° and 90° locations.



Marine grade epoxy    Aviation    Fuel delivery    Galvanized finish    Hydroseed    Fiber optic cable    Sewer/jetter

North America: **800-444-3134**  
 Europe: **+44 (0) 1536 406999**  
**www.reelcraft.com**

China: **+86 (519) 8512 2391**  
 Pacific Rim: **+63 (45) 625-6624**  
 Latin America: **260-489-1685**

Reelcraft Industries is **ISO 9001:2000** Certified Since 1996

Models listed with an icon can be shipped same day upon request when the order is received by 11:30 AM local time for quantities of 5 or fewer.

 Indiana Warehouse     California Warehouse

 Indiana & California Warehouses     Canadian Warehouse



# Large Frame Reels

## Nordic Heavy Duty Solutions

### Reelcraft's Engineered Product Solutions

#### Full Flow Design

The goose neck is contoured to match the drum diameter, which allows smooth hose wrapping and unimpeded flow.

#### Long Service Life

Swivel incorporates a permanently lubricated ball bearing.

#### Adjustable Hose Tension

The brake can be adjusted to suit the application requirements.

#### Trouble-Free Rewinding

Chain and sprocket drive ensures smooth and consistent operation.

Meets or Exceeds Military Vibration for Truck Transport test.

MIL-STD-810F  
500,000 mile equivalent

#### Long Service Life

The spool axial is supported by independent self-aligning bearing.

#### Free Rotation While Pressurized

The swing joint and spindle allows reel to freely rotate while fluid is pressurized.

#### Precise Rigid Construction

Proprietary unitized tie rods are zinc plated offering greater strength and resistance to vibration and corrosion.

#### Ultimate Corrosion Resistance

Individually powder coated components insure maximum coverage and resistance to corrosion. Stainless steel fasteners are standard.

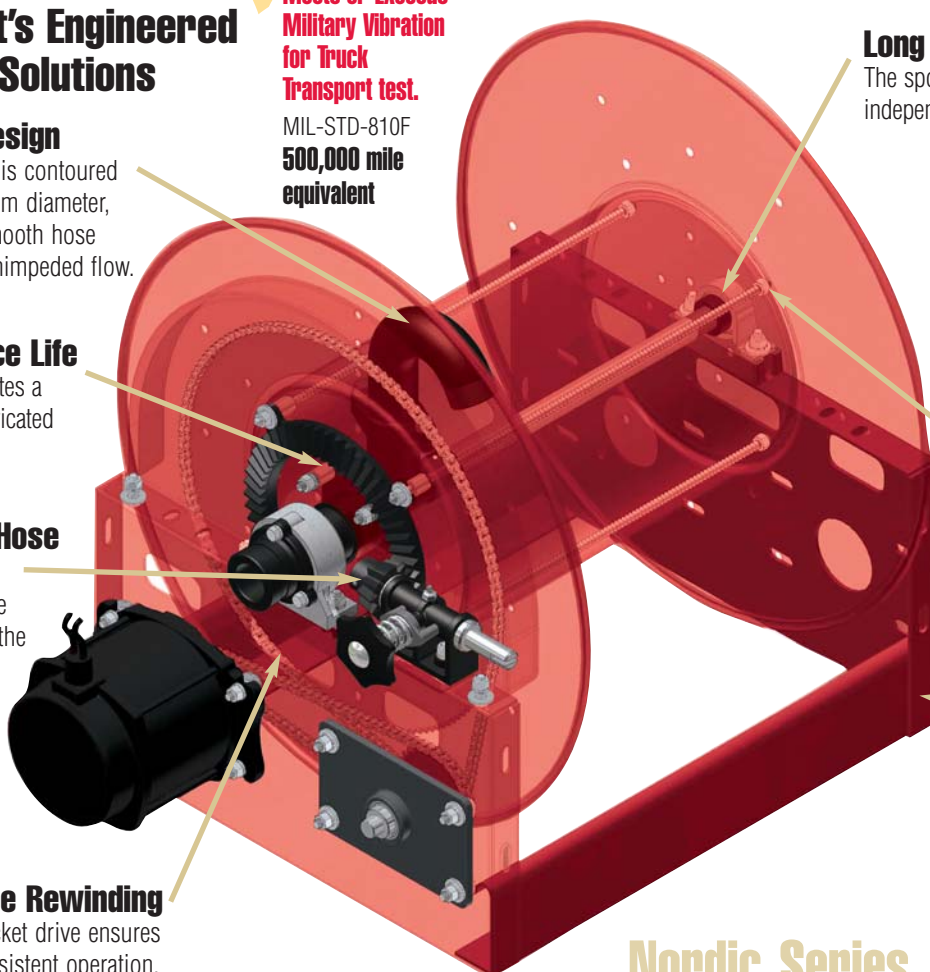

## Nordic Series

Drive Options	Series	Head Dia.	Drum Length	Thread Size	Thread Type	Thread Style	Fluid Path Material	Pressure	Inlet Style	Fluid Path Location/Direction	Color Code
<b>E</b> 12 VDC	<b>1200</b>	<b>19</b>	6" -36" in 2" increments	<b>50</b> 1/2"	<b>F</b> Female Outlet	<b>NP</b> NPT	<b>A</b> Aluminum	<b>LP</b> 0-600	<b>1</b> Straight	<b>1</b> Left Hand Top Wind	<b>R</b> Red
<b>NJ</b> 24 VDC	<b>2400</b>	<b>21</b>		<b>75</b> 3/4"	<b>FF</b> Female In/Out	<b>BP</b> BSPP	<b>D</b> Ductile Iron	<b>1K</b> 600-1000	<b>2</b> 90 Degree	<b>2</b> Left Hand Bottom Wind	<b>B</b> Black
<b>EP</b> *12 VDC Exp	<b>3900</b>	<b>23</b>		<b>10</b> 1"	<b>M</b> Male Outlet	<b>BT</b> BSPT	<b>S</b> Stainless	<b>3K</b> 1000-3000	<b>5</b> 1" LPG	<b>3</b> Right Hand Top Wind	<b>W</b> White
<b>EA</b> *115 VAC Exp	<b>3700</b>	<b>25</b>		<b>12</b> 1 1/4"	<b>MM</b> Male In/Out		<b>B</b> Bronze	<b>5K</b> 3001-5000	<b>6</b> 1 1/2" LPG	<b>4</b> Right Hand Bottom Wind	<b>G</b> Grey
<b>EJ</b> *24 VDC Exp	<b>5900</b>	<b>28</b>		<b>15</b> 1 1/2"	<b>V</b> Victaulic			<b>6K</b> 5001-6000	<b>7</b> 2" LPG		<b>S</b> Silver
<b>HD</b> Hydraulic		<b>31</b>		<b>20</b> 2"				<b>10K</b> 10,000			
<b>AF</b> 1 1/2 HP Air		<b>36</b>		<b>25</b> 2 1/2"				<b>15K</b> 15,000			
<b>AR</b> 4 HP Air		<b>39</b>		<b>30</b> 3"							
<b>BC</b> Bevel Crank		<b>46</b>		<b>40</b> 4"							
<b>HC</b> Hand Crank											
<b>S</b> Storage											
<b>CR</b> Cable Reel											

\*Exp=Explosion proof motor

Material Options/ Drive Size	Series
1/2" Pitch Chain	###5
5/8" Pitch Chain	###6
3/4" Pitch Chain	###7
Gear Driven	###9
Alum. Frame/Spool	##5#
304 S.S. Frame/Spool	##9#
316 S.S. Frame/Spool	##8#
Sewer Cleaning Reel	##15
Twin Hose	####T

**Additional Options**

Idler
Chain Guard
Roller Bracket (Top)
Roller Bracket (Bottom)
Inboard Motor
Brake
Auxiliary Bevel Crank
Hose Boss (Guide)
Junction Box
Explosion Proof Switch
Solenoid
Circuit Breaker
Control Valve

**Part No. Example: EP3900-23-28-15FFNPALP21-R00**  
 EP(12VDC Electric Explosion Proof Motor)  
 3900(Series 3900 Hose Reel)  
 -23(23" Head Dia.) -28(28" Drum Length)  
 -15(1-1/2" Thread Size) FF(Female In/Out Thread Type)  
 NP(NPT Thread Style) A(Aluminum Fluid Path)  
 LP(0-600 PSI) 2(90° Inlet)  
 1(Left Hand Top Wind Fluid Path Location/Direction)  
 R(Red)

**NOTE:** Not all options available in every combination. Please contact manufacturer for price and availability.

North America: 800-444-3134  
 Europe: +44 (0) 1536 406999  
 www.reelcraft.com

China: +86 (519) 8512 2391  
 Pacific Rim: +63 (45) 625-6624  
 Latin America: 260-489-1685





CA33112 L

Hand  
Crank

### Hand Crank & Motor Driven Air/Water/Oil - 1/2", 3/4", 1" I.D.

Reelcraft's Series 30000 reels are designed for rugged, heavy duty applications requiring long lengths of hose and large storage capacity. All-bolted unitized construction with no welds to fatigue. Full flow swivel and heavy gauge steel frame, spool and drum ensure longest service life.

**Made in USA**

**Note:** Weights listed are for crank driven - Add for power driven, electric - all explosion proof 45 lb. (20.41 kg); 12 Volt D.C. 1/3 H.P. 30 lb. (13.61 kg); Air 6 AM 36 lb. (16.33 kg).  
\*Note: capacity chart is reference only.

For all metric thread connections over 1/2" add the suffix number 70 to indicate BSPT threads - example CA33112 M70.

DIMENSIONS & SPECS				
HOSE I.D.	1/2"	3/4"	1"	
	(12.70mm)	(19.05mm)	(25.40mm)	
HOSE O.D.	.854"	1.188"	1.380"	
	(21.5mm)	(30.2mm)	(35.0mm)	
"B" WIDTH	WEIGHT		HOSE CAPACITY	
6"	38 lb	100'	50'	N/A
(153 mm)	(18 kg)	(31 m)	(16 m)	
12"	46 lb	200'	100'	N/A
(305 mm)	(21 kg)	(61 m)	(31 m)	
18"	54 lb	325'	175'	100'
(458 mm)	(25 kg)	(99 m)	(54 m)	(31 m)

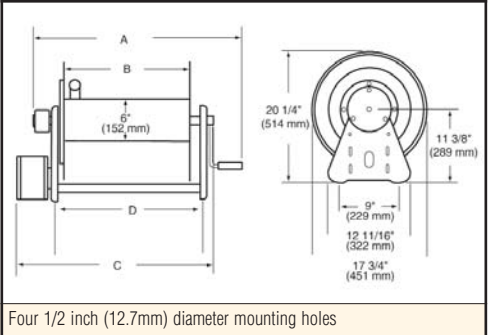

### SPECIFICATIONS

MODEL	HOSE I.D.		HOSE O.D.		(F)NPTF REEL INLET	CAPACITY		WEIGHT		PRESSURE		A	B	C	D			
	in / mm	in / mm	in / mm	in / mm		ft / m	lbs / kg	psi / bar	psi / bar	in / mm	in / mm	in / mm	in / mm					
<b>HAND CRANK</b>																		
CA32106 L	1/2	13	.845	21.5	1/2	100	31	42	19	1000	69	19	483	6	153	N/A	9 <sup>3</sup> / <sub>4</sub>	248
CA32112 L	1/2	13	.845	21.5	1/2	200	61	49	22	1000	69	25	635	12	305	N/A	15 <sup>3</sup> / <sub>4</sub>	400
CA33106 L	3/4	19	1.188	30.2	3/4	50	16	43	20	1000	69	19	483	6	153	N/A	9 <sup>3</sup> / <sub>4</sub>	249
CA33112 L	3/4	19	1.188	30.2	3/4	100	31	42	19	1000	69	25	635	12	305	N/A	15 <sup>3</sup> / <sub>4</sub>	400
CA33118 L	3/4	19	1.188	30.2	3/4	175	54	56	25	1000	69	31	787	18	458	N/A	21 <sup>3</sup> / <sub>4</sub>	553
CA37118 L	1	25	1.380	35.0	1	100	31	58	26	300	21	34	864	18	458	N/A	21 <sup>3</sup> / <sub>4</sub>	553
CA32112 M	1/2	13	.845	21.5	1/2	200	61	49	22	3000	207	25	635	12	305	N/A	15 <sup>3</sup> / <sub>4</sub>	400
CA33112 M	3/4	19	1.188	30.2	3/4	100	31	53	24	3000	207	25	635	12	305	N/A	15 <sup>3</sup> / <sub>4</sub>	400
CA33118 M	3/4	19	1.188	30.2	3/4	175	54	54	25	3000	207	31	787	18	458	N/A	21 <sup>3</sup> / <sub>4</sub>	553

### ELECTRIC MOTOR DRIVEN REELS

EA32118 L12D	1/2	13	.845	21.5	1/2	325	99	71	32	1000	69	N/A	18	458	29 <sup>5</sup> / <sub>8</sub>	753	21 <sup>3</sup> / <sub>4</sub>	553
EA33112 L12D	3/4	19	1.188	30.2	3/4	100	31	70	31	1000	69	N/A	12	305	23 <sup>5</sup> / <sub>8</sub>	600	15 <sup>3</sup> / <sub>4</sub>	400

All 30000 series reels are supplied without hose. Assemblies quoted upon request. \*Series 37000 reels do not have a gooseneck. NOTE: Many more reel models available in addition to chart. Please call manufacturer for details on models not listed.

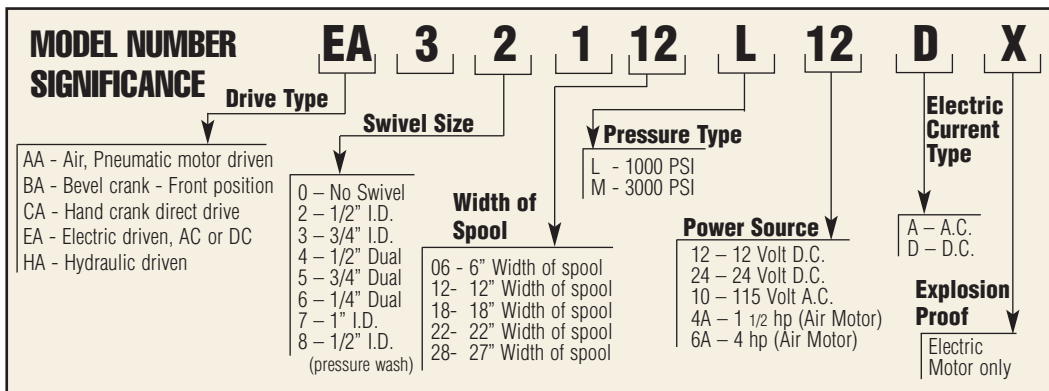

- ✓ Adjustable spool rotation drag that eliminates hose backlash
- ✓ Nickel-plated swivel with four "O" ring options: AFLAS (std), Buna, Viton® or -EPR\* seals \*Standard swivel
- ✓ Optional lock pin to prevent spool rotation when the reel is not in use S600874
- ✓ Temperature operating range from -20° F (-29° C) to +250° F (121° C)

**NOTE:** This chart is for reference purposes only. Reels cannot be ordered by selecting from this chart. Please see selection charts or consult manufacturer for additional models not listed in selection chart or for any questions about option combinations.

North America: **800-444-3134**

Europe: **+44 (0) 1536 406999**

**www.reelcraft.com**

China: **+86 (519) 8512 2391**

Pacific Rim: **+63 (45) 625-6624**

Latin America: **260-489-1685**

Reelcraft Industries is  
**ISO 9001:2000**  
Certified Since 1996

Models listed with an icon can be shipped same day upon request when the order is received by 11:30 AM local time for quantities of 5 or fewer.



Indiana Warehouse



California Warehouse



Indiana & California  
Warehouses



Canadian Warehouse

# Large Frame Reels Nordic Series 2400

## Heavy Duty Large Frame Reels Nordic Series 1200

1" Fluid Path for 1/2" through 1" I.D. Hose

**Rewind:** Direct crank rewind or chain and sprocket drive powered by A.C. or D.C. electric motor, compressed air motor or hydraulic motor. Crank is not supplied on power rewind models. A pin lock assembly is optional on manual rewind reels. A 3/8" pitch chain is standard.

**Inlet:** 1/2" up to 1" female/male NPT 90° swivel joint. Straight swivel joint may be specified at extra cost.

**Gooseneck:** 1/2", 3/4", 1" female NPT. Other sizes and/or threads, including garden hose thread, can be furnished when specified.

The standard color for this series is red.

**NEW!**

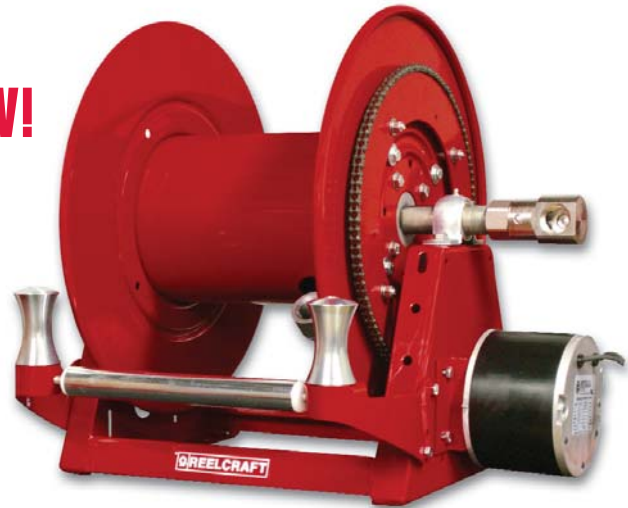

Nordic Series 1200

Shown with optional three-way roller bracket.

Nonexplosion-proof motor is standard "E" (pictured). Explosion proof (EP) motor is available upon request.

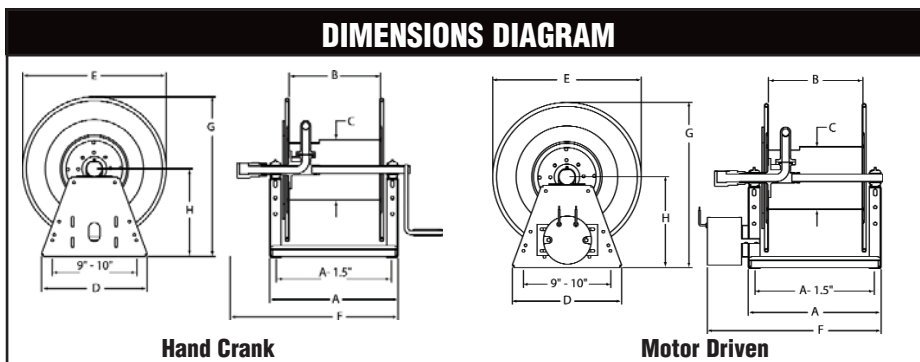

Product temperatures range from -20° to +225°F and standard pressures to 3000 PSI. Other temperatures or pressures can be furnished at extra cost; consult manufacturer.

**Made in USA**

HOSE I.D.		1/2	3/4	1	SPECIFICATIONS - HOSE CAPACITY AND REEL DIMENSIONS														
HOSE O.D.		0.845	1.18	1.4	KEY: CRK = hand crank; "E" = nonexplosion-proof electric motor; EP = explosion-proof motor; AIR = air motor; BEVEL = bevel crank														
MODEL	HOSE LENGTH	WT CRANK*	WT MOTOR*	WT BEVEL*	A	B	C	D	E	F CRK	F "E"	F EP	F AIR	F BEVEL	G	H			
1200-19-6	ft	100	50	35	41 LB	58 LB	48 LB	11	6	8	14	19	22	16.5	18.5	16	22	21	11.6
	m	30	15	11	19 KG	26 KG	22 KG	279	152	203	356	483	559	419	470	406	559	533	295
1200-19-12	ft	200	100	70	43 LB	60 LB	50 LB	17	12	8	14	19	28	22.5	24.5	22	28	21	11.6
	m	61	30	21	20 KG	27 KG	23 KG	432	305	203	356	483	711	572	622	559	711	533	295
1200-19-18	ft	300	150	105	44 LB	61 LB	51 LB	23	18	8	14	19	34	28.5	30.5	28	34	21	11.6
	m	91	46	32	20 KG	28 KG	23 KG	584	457	203	356	483	864	724	775	711	864	533	295
1200-19-22	ft	365	180	125	45 LB	62 LB	52 LB	27	22	8	14	19	38	32.5	34.5	32	38	21	11.6
	m	111	55	38	20 KG	28 KG	24 KG	686	559	203	356	483	965	826	876	813	965	533	295
1200-19-28	ft	465	230	160	46 LB	63 LB	53 LB	33	28	8	14	19	44	38.5	40.5	38	44	21	11.6
	m	142	70	49	21 KG	29 KG	24 KG	838	711	203	356	483	1118	978	1029	965	1118	533	295
1200-23-6	ft	150	75	50	49 LB	66 LB	56 LB	11	6	11.25	15.25	23	22	16.5	18.5	16	22	25.1	13.6
	m	46	23	15	22 KG	30 KG	25 KG	279	152	286	387	584	559	419	470	406	559	638	345
1200-23-12	ft	300	150	100	51 LB	68 LB	58 LB	17	12	11.25	15.25	23	28	22.5	24.5	22	28	25.1	13.6
	m	91	46	30	23 KG	31 KG	26 KG	432	305	286	387	584	711	572	622	559	711	638	345
1200-23-18	ft	450	225	150	52 LB	69 LB	59 LB	23	18	11.25	15.25	23	34	28.5	30.5	28	34	25.1	13.6
	m	137	69	46	24 KG	31 KG	27 KG	584	457	286	387	584	864	724	775	711	864	638	345
1200-23-22	ft	550	275	180	53 LB	70 LB	60 LB	27	22	11.25	15.25	23	38	32.5	34.5	32	38	25.1	13.6
	m	168	84	55	24 KG	32 KG	27 KG	686	559	286	387	584	965	826	876	813	965	638	345
1200-23-28	ft	700	350	230	54 LB	71 LB	61 LB	33	28	11.25	15.25	23	44	38.5	40.5	38	44	25.1	13.6
	m	213	107	70	24 KG	32 KG	28 KG	838	711	286	387	584	1118	978	1029	965	1118	638	345

\*Estimated weight on carbon steel frame.

North America: 800-444-3134  
Europe: +44 (0) 1536 406999  
www.reelcraft.com

China: +86 (519) 8512 2391  
Pacific Rim: +63 (45) 625-6624  
Latin America: 260-489-1685





### Heavy Duty Large Frame Reels Nordic Series 2400

1/2", 3/4" or 1" Fluid Path for 1/2" through 1" I.D. Hose

**Rewind:** Gear-drive rewind (new) or chain and sprocket drive powered by A.C. or D.C. electric motor, compressed air motor or hydraulic motor.

**Inlet:** 1/2" up to 1" female/male NPT 90° swivel joint. Straight swivel joint may be specified at extra cost.

**Gooseneck:** 1/2" up to 1" female/male NPT. Other sizes and/or threads, including male NST and male garden hose thread, can be furnished when specified.

Product temperatures from -20° to +225°F and standard pressures to 3000 p.s.i. Reels to operate at other temperatures or pressures can be furnished at extra cost, consult manufacturer. The standard color for this series is red or gray. ADD 12" to E dimension when crank is in rewind position.

**NEW!**  
Gear drive  
option



**1/2" pitch chain  
now standard**

Shown with optional  
bevel crank.

**Made in USA**

#### DIMENSIONS DIAGRAM

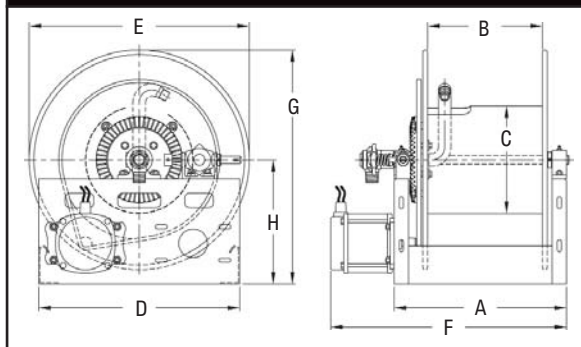

### Fire Service / Booster Reels

The **aluminum Series 2400** reel for booster hose is corrosion-resistant and weighs up to 50% less than standard steel booster reels. Features include an aluminum spool and frame assembly, plated steel fluid path and plated sprocket and fasteners. **No painting or finishing is required.**

Nordic Series 2450



HOSE I.D.	in	1/2	3/4	1	SPECIFICATIONS - HOSE CAPACITY AND REEL DIMENSIONS																			
		mm	13	19	25	KEY: CRK = hand crank; ELC = electric motor; EXP = explosion-proof motor; AIR = air motor; BEVEL = bevel crank																		
HOSE O.D.	in	.875	1.281	1.563	MODEL	HOSE LENGTH (other std. lengths available)				EST. WEIGHT	A	B	C	D	E CRK	E ELC	E AIR	E HYD	F CRK	F ELC	F AIR	F HYD	G	H
		mm	22	33	40		ft	m	ft	m	ft	m	ft	m	ft	m	ft	m	ft	m	ft	m	ft	m
2400-19-16	ft	200	100	50	70 LB	in	21	16	11.25	21	21	21	21	22	21	26	29	26	28	22.5	13			
	m	61	30	15	32 KG	mm	533	406	286	533	533	533	533	559	533	660	737	660	711	572	330			
2400-23-14	ft	315	150	100	74 LB	in	20	14	11.25	21	23	23	24	23	24	27	24	26	24.5	13				
	m	96	46	30	34 KG	mm	508	356	286	533	584	584	610	584	610	686	610	660	622	330				
2400-23-18	ft	485	240	150	78 LB	in	24	18	11.25	21	23	23	24	23	24	28	31	28	30	24.5	13			
	m	148	73	46	35 KG	mm	610	457	286	533	584	584	610	584	711	787	711	762	622	330				
2400-23-20	ft	535	260	165	80 LB	in	26	20	11.25	21	23	23	24	23	24	30	33	30	32	24.5	13			
	m	163	79	50	36 KG	mm	660	508	286	533	584	584	610	584	762	838	762	813	622	330				
2400-23-24	ft	625	300	200	84 LB	in	30	24	11.25	21	23	23	24	23	24	34	37	34	36	24.5	13			
	m	191	91	61	38 KG	mm	762	610	286	533	584	584	610	584	864	940	864	914	622	330				
2400-25-8	ft	235	125	60	72 LB	in	14	8	11.25	21	25	25	25	25	25	18	21	18	20	26.5	14			
	m	72	38	18	33 KG	mm	356	203	286	533	635	635	635	635	457	533	457	508	673	356				
2400-25-14	ft	450	225	110	74 LB	in	20	14	11.25	21	25	25	25	25	25	24	27	24	26	26.5	14			
	m	137	69	34	34 KG	mm	508	356	286	533	635	635	635	635	610	686	610	660	673	356				
2400-31-8	ft	435	185	125	74 LB	in	14	8	11.25	24	31	31	31	31	31	18	21	18	20	32.5	17			
	m	133	56	38	34 KG	mm	356	203	286	610	787	787	787	787	457	533	457	508	826	432				
2400-31-10	ft	540	235	165	76 LB	in	16	10	11.25	24	31	31	31	31	31	20	23	20	22	32.5	17			
	m	165	72	50	34 KG	mm	406	254	286	610	787	787	787	787	508	584	508	559	826	432				
2400-31-16	ft	900	400	300	80 LB	in	22	16	11.25	24	31	31	31	31	31	26	29	26	28	32.5	17			
	m	274	122	91	36 KG	mm	559	406	286	610	787	787	787	787	660	737	660	711	826	432				

Refer to page 3 to build a complete model number. Refer to chart on page 7 for weight adders.

North America: **800-444-3134**

Europe: **+44 (0) 1536 406999**

**www.reelcraft.com**

China: **+86 (519) 8512 2391**

Pacific Rim: **+63 (45) 625-6624**

Latin America: **260-489-1685**

Reelcraft Industries is  
**ISO 9001:2000**  
Certified Since 1996

Models listed with an icon can be shipped same day upon request when the order is received by 11:30 AM local time for quantities of 5 or fewer.



Indiana Warehouse



California Warehouse



Indiana & California  
Warehouses



Canadian Warehouse

# Large Frame Reels Nordic Series 3900

## Heavy Duty Large Frame Reels Nordic Series 3900

1½" Fluid Path for 1" through 1½" I.D. Hose

**Rewind:** Gear-drive rewind (new) or chain and sprocket drive powered by A.C. or D.C. electric motor, compressed air motor or hydraulic motor.

**Inlet:** 2" straight victaulic with 1½" female NPT straight swivel joint is standard. 2" victaulic 90° with 1½" NPT female available at extra cost.

**Gooseneck:** 1", 1¼" and 1½" female/male NPT outlet. Other sizes and/or threads can be furnished and must be specified.

ADD 12" to E dimension when crank is in rewind position.  
The standard color for this series is red or gray.

**1/2" pitch chain  
now standard**

**NEW!  
Gear drive  
option**

Shown with optional  
bevel crank.



**Made in USA**

Standard seals maximum temperature 174° F (79° C) and minimum temperature -20° F (-29° C). Extreme temperature seals maximum temperature 400° F (204° C) and minimum temperature -50° F (-45° C) and standard pressures to 600 PSI. Other temperatures or pressures can be furnished at extra cost, consult manufacturer.

### DIMENSIONS DIAGRAM

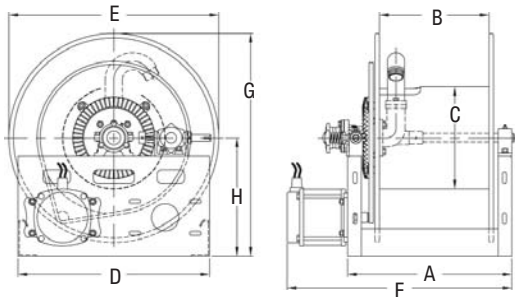

**Note: Weights shown in chart  
are for crank rewind models.**

Prefix	Type	LB / KG
EP	Electric	42 / 19
A	Air	26 / 12
H	Hyd	26 / 12

**Add these amounts and model  
number prefix for power rewind  
models.**

HOSE I.D.	in	1	1 1/4	1 3/8	1 1/2	SPECIFICATIONS - HOSE CAPACITY AND REEL DIMENSIONS															
		mm	25	32	35															38	
HOSE O.D.	in	1.563	1.813	2.000	2.063	KEY: CRK = hand crank; ELC = electric motor; HYD = hydraulic motor; AIR = air motor; BEVEL = bevel crank															
		mm	40	46	51															52	
MODEL	HOSE LENGTH (other std. lengths available)				EST. WEIGHT	A	B	C	D	E CRK	E ELC	E AIR	E HYD	F CRK	F ELC	F AIR	F HYD	G	H		
3900-19-16	ft	55	45	45	40	90 LB	in	22	16	11¼	21	21	21	22	21	26	29	26	28	22½	13
	m	17	14	14	12	41 KG	mm	559	406	286	533	533	533	559	533	660	737	660	711	572	330
3900-19-20	ft	70	65	60	55	93 LB	in	26	20	11¼	21	21	21	22	21	30	33	30	32	22½	13
	m	21	20	18	17	42 KG	mm	660	508	286	533	533	533	559	533	762	838	762	813	572	330
3900-23-12	ft	95	60	55	50	87 LB	in	18	12	11¼	21	23	23	24	23	22	25	22	24	24½	13
	m	29	18	17	15	39 KG	mm	457	305	286	533	584	584	610	584	559	635	559	610	622	330
3900-23-18	ft	155	90	90	80	93 LB	in	24	18	11¼	21	23	23	24	23	28	31	28	30	24½	13
	m	47	27	27	24	42 KG	mm	610	457	286	533	584	584	610	584	711	787	711	762	622	330
3900-23-20	ft	165	105	100	95	95 LB	in	26	20	11¼	21	23	23	24	23	30	33	30	32	24½	13
	m	50	32	30	29	42 KG	mm	660	508	286	533	584	584	610	584	762	838	762	813	622	330
3900-23-26	ft	220	120	110	105	100 LB	in	32	26	11¼	21	23	23	24	23	36	39	36	38	24½	13
	m	67	37	34	32	45 KG	mm	813	660	286	533	584	584	610	584	914	991	914	965	622	330
3900-23-28	ft	240	145	140	135	103 LB	in	34	28	11¼	21	23	23	24	23	38	41	38	40	24½	13
	m	73	44	43	41	47 KG	mm	864	711	286	533	584	584	610	584	965	1041	965	1016	622	330
3900-23-36	ft	320	190	180	175	111 LB	in	42	36	11¼	21	23	23	24	23	46	49	46	48	24½	13
	m	98	58	55	53	50 KG	mm	1067	914	286	533	584	584	610	584	1168	1245	1168	1219	622	330
3900-25-12	ft	95	85	55	50	89 LB	in	18	12	11¼	21	25	25	25	25	22	25	22	24	26½	14
	m	29	26	17	15	40 KG	mm	457	305	286	533	635	635	635	635	559	635	559	610	673	356
3900-25-20	ft	165	155	100	95	97 LB	in	26	20	11¼	21	25	25	25	30	33	30	32	26½	14	
	m	50	47	30	29	44 KG	mm	660	508	286	533	635	635	635	635	762	838	762	813	673	356
3900-31-12	ft	210	155	115	105	92 LB	in	18	12	11¼	24	31	31	31	31	22	25	22	24	32½	17
	m	64	47	35	32	42 KG	mm	457	305	286	610	787	787	787	787	559	635	559	610	826	432
3900-31-16	ft	305	205	155	150	96 LB	in	22	16	11¼	24	31	31	31	31	26	29	26	28	32½	17
	m	93	62	47	46	44 KG	mm	559	406	286	610	787	787	787	787	660	737	660	711	826	432
3900-31-20	ft	365	275	200	190	100 LB	in	26	20	11¼	24	31	31	31	31	30	33	30	32	32½	17
	m	111	84	61	58	45 KG	mm	660	508	286	610	787	787	787	787	762	838	762	813	826	432

Refer to page 3 to build a complete model number.

North America: **800-444-3134**  
Europe: **+44 (0) 1536 406999**  
[www.reelcraft.com](http://www.reelcraft.com)

China: **+86 (519) 8512 2391**  
Pacific Rim: **+63 (45) 625-6624**  
Latin America: **260-489-1685**



# Rely on Reelcraft™

Built Better to Perform Better™

Truck provided  
by Firehouse  
Concepts



Motor Driven  
Series 300000



## North America and Corporate Headquarters

2842 E. Business Hwy 30  
Columbia City, IN 46725-0248  
Ph: 800-444-3134 • Fax: 800-444-4587  
Ph: 260-248-8188 • Fax: 260-248-2605  
reelcraft@reelcraft.com  
[www.reelcraft.com](http://www.reelcraft.com)

## Latin America and the Middle East

Thompson International, Inc.  
P.O. Box 12958, Ft. Wayne, IN 46866  
Ph: 260-489-1685 • Fax: 260-489-0203  
info@t-i-i.com  
[www.reelcraft.com/latinamerica](http://www.reelcraft.com/latinamerica)

## China

Reelcraft Changzhou Co., Ltd.  
Building C, No. 229 HeHai West Road  
Changzhou, Jiangsu, China 213022  
Ph: +86 (519) 8512 2391 ext. 8002  
Fax: +86 (519) 8512 9309  
rco@reelcraftchina.com  
[www.reelcraft.com/china](http://www.reelcraft.com/china)

## Europe

Unit 17 • Cronin Courtyard • Weldon South Industrial Estate  
Corby • Northamptonshire • NN18 8AG United Kingdom  
Ph: +44 (0) 1536 406999 • Fax: +44 (0) 1536 406777  
europe@reelcraft.com  
[www.reelcraft.com/europe](http://www.reelcraft.com/europe)

## Pacific Rim

P.O. Box 53776, Clark Freeport Zone, Philippines 2023  
Ph: +63 (45) 625-6624 • Fax: +63 (45) 321-0643  
rap@comclark.com  
[www.reelcraft.com/asia](http://www.reelcraft.com/asia)

## Australia

PO Box 6463 BC, Blacktown • NSW 2148, Australia  
Ph: +61 (2) 9621 8988 • Fax: +61 (2) 9621 7688  
sales@recoila.com  
[www.reelcraft.com](http://www.reelcraft.com)

[reelcraft.com](http://reelcraft.com)

Form # FIRE 04/10

