

Level Switches

Level Float Switch

- ◆ LEN Series
- ◆ RL Series

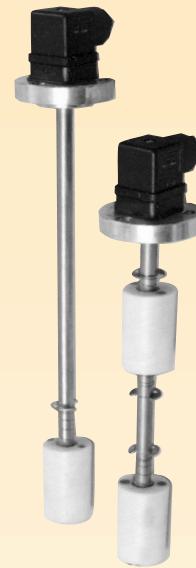

Visual/Electrical Low Level

- ◆ LV/E1 Series

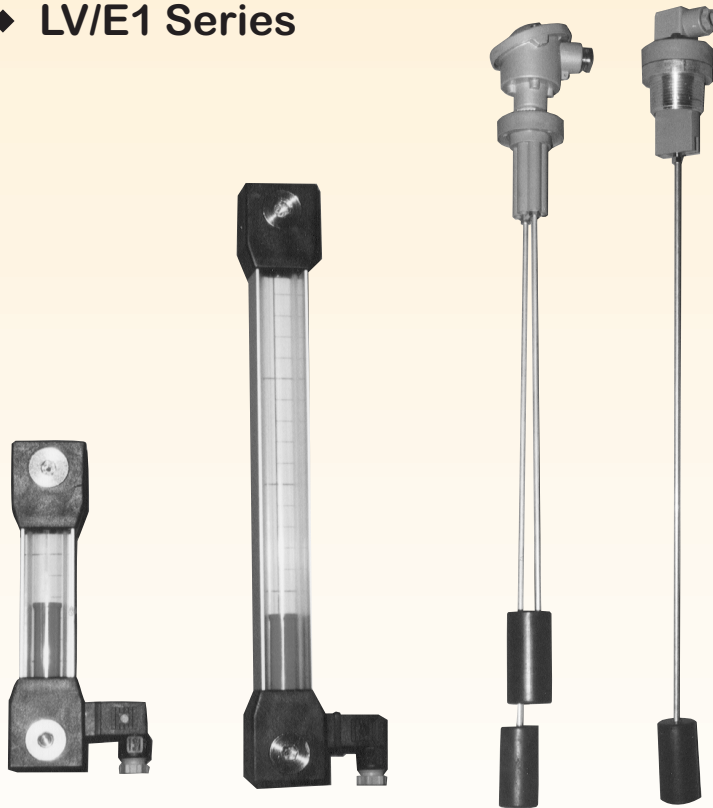

MP FILTRI (CANADA) INC.

Level Float Switch - LEN Series

Description

- ◆ The electromagnetic level indicator activates an electric signal when the fluid inside the tank reaches a stated level.
- ◆ LEN series is available with three hole flanges or with a 1" BSP threaded connection, with 1 or 2 floats, in a standard range of lengths.

The float traveling up and down the tube contains a magnet: when the float reaches the reed switch enclosed in the tube, the magnet causes the contact to close (or open).

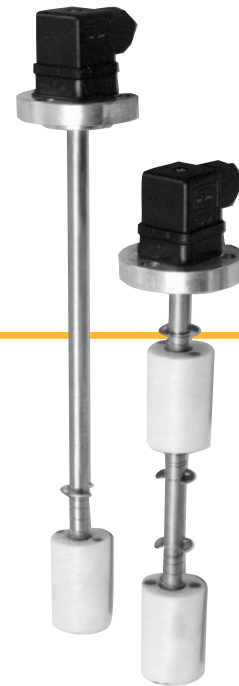

Technical Data

- ◆ Materials:
 - Connector: Plastic
 - Flange: Aluminum
 - Tube: Brass
 - Float: Plastic
- ◆ Electrical Data:
 - Power communicable to DC: 60W
 - Power communicable to AC: 80VA
 - DC current intensity: 1.3A
 - AC current intensity: 2A
 - Communicable voltage: 250V
 - Frequency: 50 Hz/60 Hz
 - Capacitance of open contacts: 4pF
 - Insulation resistance 10 ohms
 - Connector protection: IP 65
- ◆ N.C. to N.O. Conversion: To convert an "LEN" from N.C. to N.O. or vice versa, remove the bottom "C" clip on the rod, turn the float upside down and replace both the float and "C" clip.
- ◆ Working Pressure: 40 PSI
For higher pressure, please consult Technical Dept.
- ◆ Working Temperature: From -20°C to +100°C
- ◆ Warning: These indicators are designed for vertical installation. The float must be at least 35 mm away from any ferrous surface.

Installation Data LEN Series

◆ Dimensions 1 Float

Size	H(mm)
150	150
200	200
250	250
350	350

◆ Electrical Diagrams

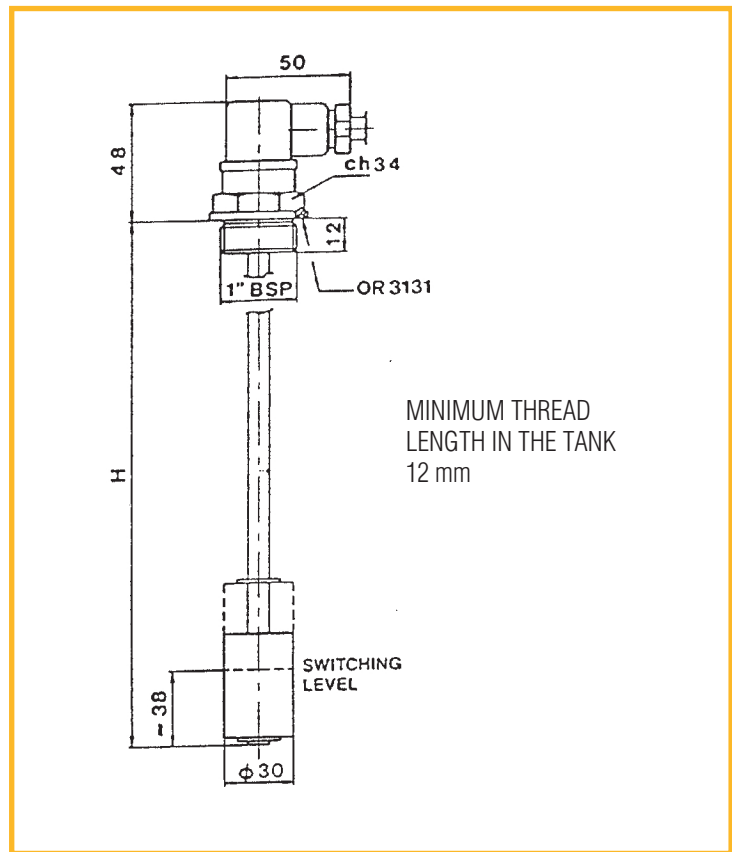
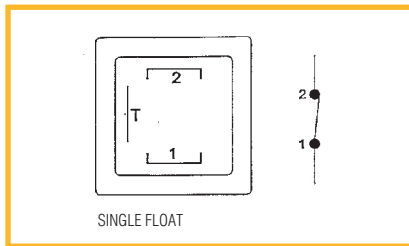

5-2

◆ Dimensions 2 Floats

Size	H(mm)	H1(mm)
200	200	95
250	250	105
350	350	115
400	400	115
500	500	125

◆ Electrical Diagrams

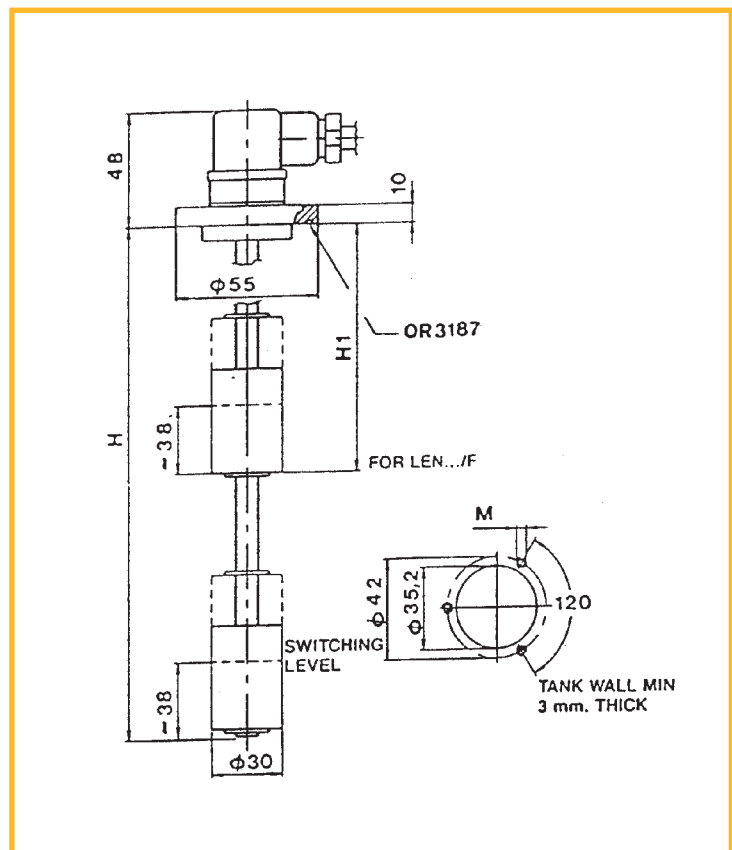
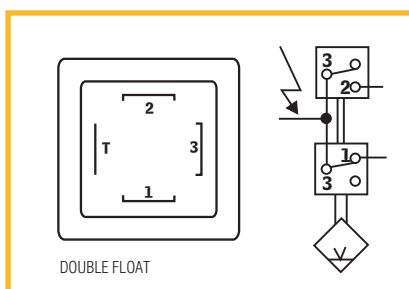

Ordering Information LEN Series

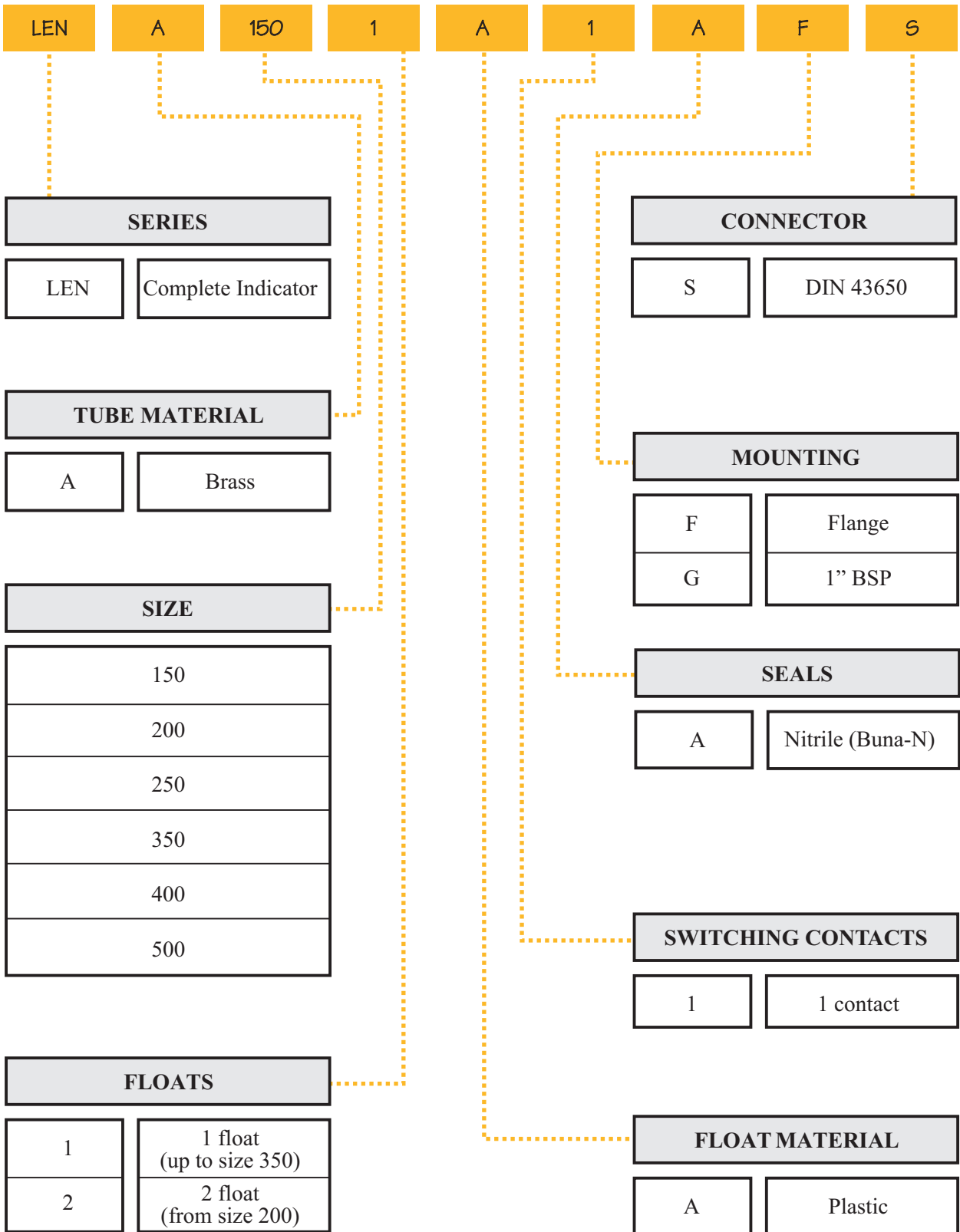

Level Float Switch - RL Series

Description

- ◆ Rapid Level Float Switch. Revolutionary new series of electro-magnetic level gauges.
- ◆ Packed in "Kit" form. Only a few seconds are required to obtain the desired length: just cut the control rod to length.
- ◆ There are no electrical components submersed in the fluid.
- ◆ Can be used in heavily contaminated fluids and refrigerating oils. Tolerates the presence of metallic particles.
- ◆ Multiple switching options are available to customize your system.
- ◆ Models suitable for high temperatures and corrosive liquids are available.

5-4

Technical Data

- ◆ Wiring Schematics: (absence of fluid)

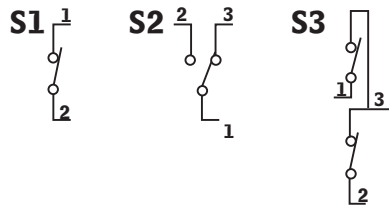

- ◆ Switch Specifications: Open or closed contacts switch
Standard: 3A. 60W. 60 V.A. 250V
On request: 5A. 250 V.A 250V

- ◆ Exchange Contact Switch: 1 A 30W. 60 V.A. 220V

- ◆ Mounting Pattern F3:

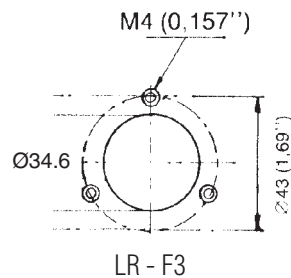

- ◆ Each level is supplied outfitted with screws and oiltight gasket

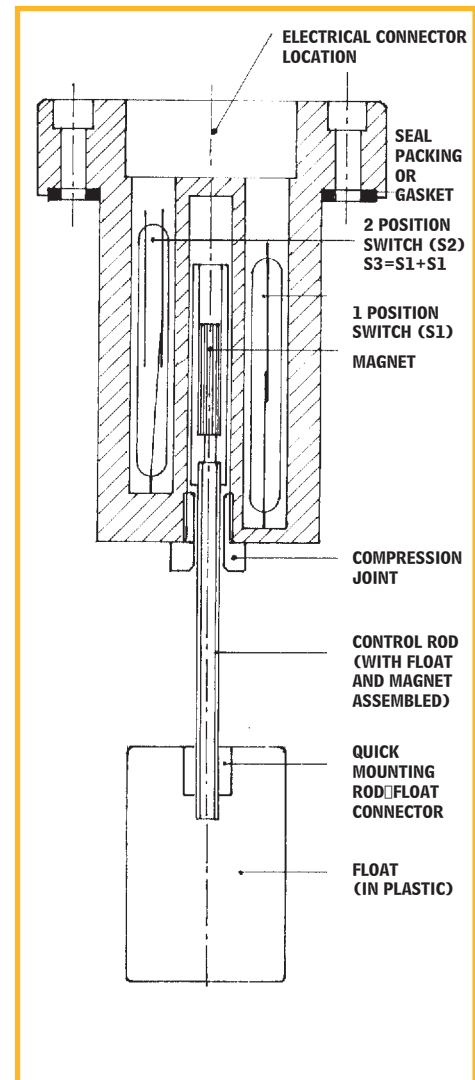

- ◆ Each level is supplied outfitted with screws and oiltight gasket

How To Cut The Rapid Level Rod

L/L1	A	B
120	116	116
140	137	137
160	158	158
180	179	179
200	200	200
220	221	221
240	242	242
260	263	263
280	284	284
300	305	305
320	326	326
340	347	347
360	368	368
380	389	389
400	410	410
420	431	431
440	452	452
460	473	473
480	494	494
500	515	515
520	511	536
540	532	557
560	553	578
580	574	599
600	595	620
620	616	641
640	637	662
660	658	683
680	679	704
700	700	725
720	721	746
740	742	767
760	763	788
780	784	809
800	805	830
820	826	851

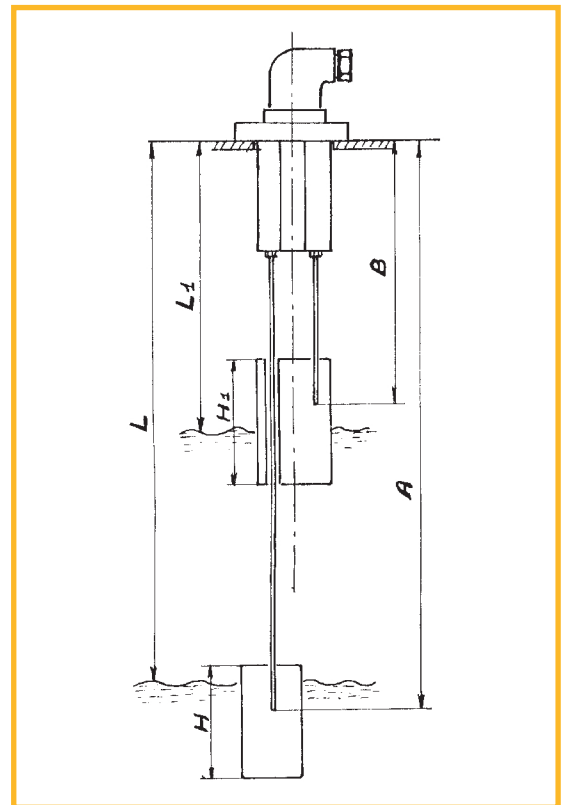

L/L1	A	B
840	874	872
860	868	
880	889	
900	910	
920	931	
940	952	
960	973	
980	994	
1000	1015	

- ◆ L = Liquid Level in mm
A = Minimum Rod Level in mm
B = Maximum Rod Level in mm
- ◆ H = 60 (L = 120:500 mm)
H = 90 (L = 501:1000 mm)
H1 = 70 (L = 120:1000 mm)
H1 = 33 (L = 85 mm)
- ◆ When measuring length of rod for cutting, Don't forget to keep the rod extended!

RL/G1 Series - Single Float

Description

- ◆ Packed in a kit form which includes the head/connector assembly, control rod and float.
- ◆ Switches are in the head assembly thus there are no wires to position inside the control rod. The control rod is stainless steel and can be cut to length easily.
- ◆ The float is fixed to the control rod and does not contain any magnets. This eliminates the collection of ferrous material present in some fluids.
- ◆ The control rod and float move as one piece into the head assembly to actuate the switches.
- ◆ Standard model is supplied with control rod closing the switch with falling oil level. If you need open contacts add "A" to the standard code. ie: RLG1-F3-S3 "A"

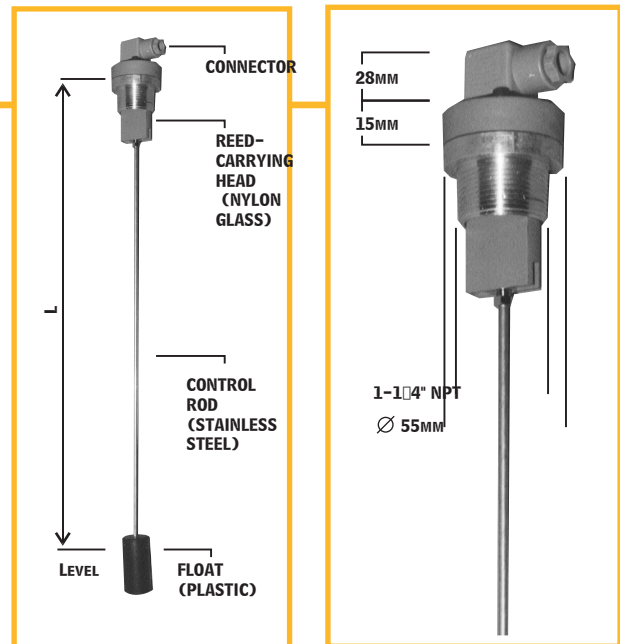

- ◆ For lengths over 500 mm or in systems with turbulence in the tank, specify type "R" reinforced rods.
- ◆ Mounting connection: T3: 1-1/4" NPT thread
F3: Flange 3 mounting holes

RL/G2 Series - Double Float

Description

- ◆ The RL/G2's head accepts two control rods. Each control rod activates a separate switch. Each switch can be wired with S1, S2, S3, configuration. This option allows a wide variety of signal options.
- ◆ The standard model is supplied with control rod 1 closing the switch contacts with falling oil level and control rod 2 closing the switch contacts with rising oil level.
- ◆ For open switch contacts add "A" to the standard code.
- ◆ For lengths over 500mm or in systems with turbulence in the tank, specify the "R" reinforced rod.
- ◆ Mounting Connection: T3 = 1-1/4" NPT thread
F3 = Flange, 3 mounting holes.

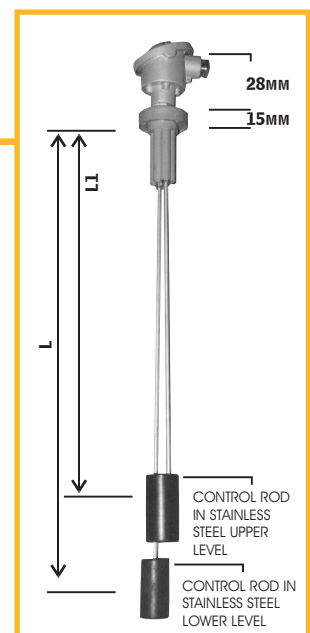

RL/L Series - Side Mount

Description

- ◆ Rapid Level lateral electro-magnetic levels packed in "Kit" form.
- ◆ This model mounted on the side of the tank, has the same basic design as the tank top version.
- ◆ Unlike the tank top models, the distance between the first and second signal is not fixed. As the length of the control rod increases the distance between the two signals increases (see graph).

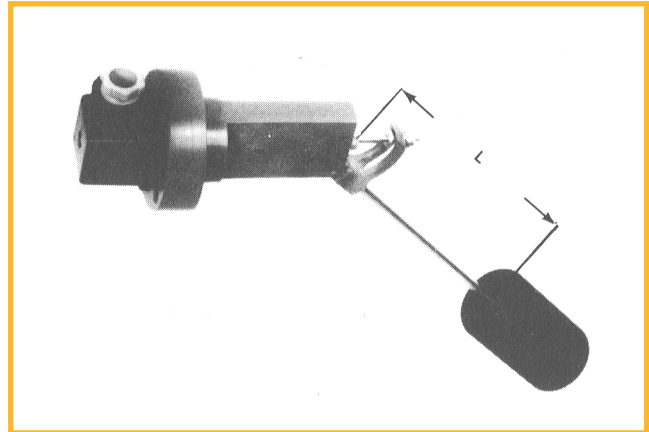

- ◆ Example using graph:

The hydraulic pump is allowed to operate through the cross hatched range. When the oil level reaches line 1 a low oil level warning signal is generated. When the oil level drops to line 3 the system is automatically shut down.

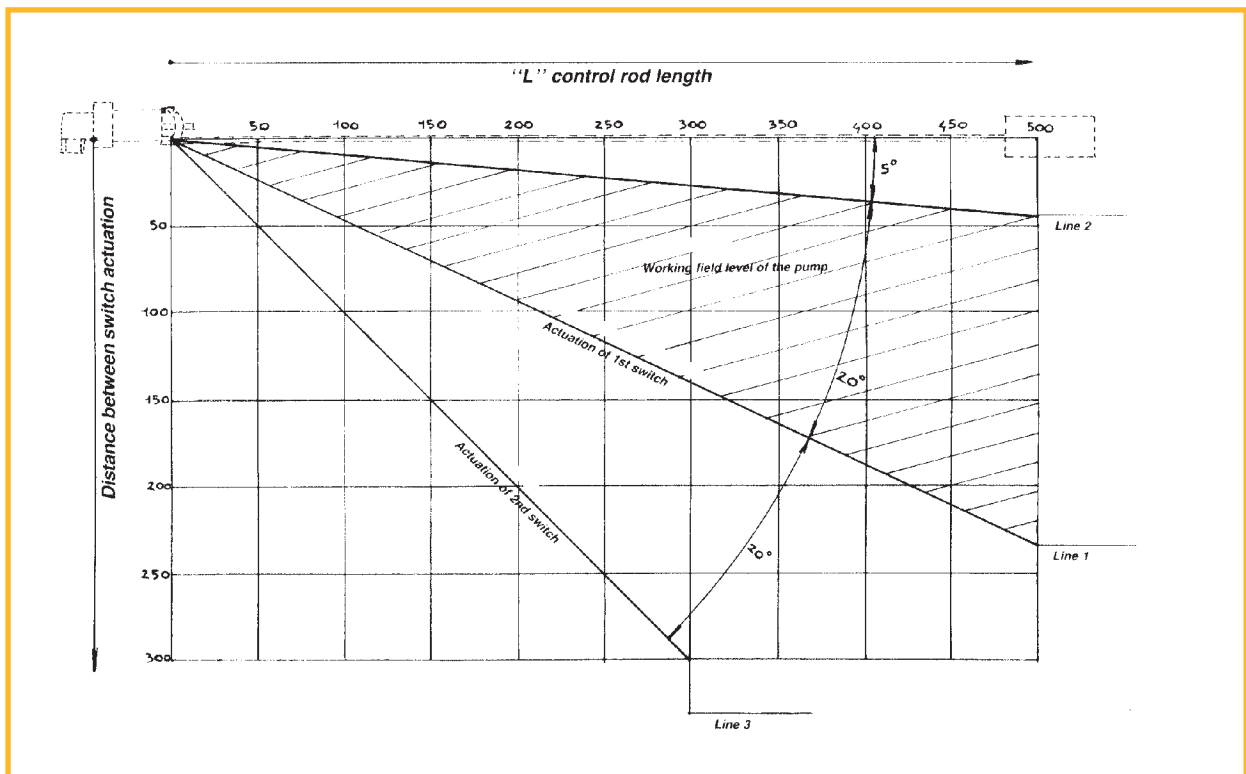

Ordering Information RL Series

Single Float

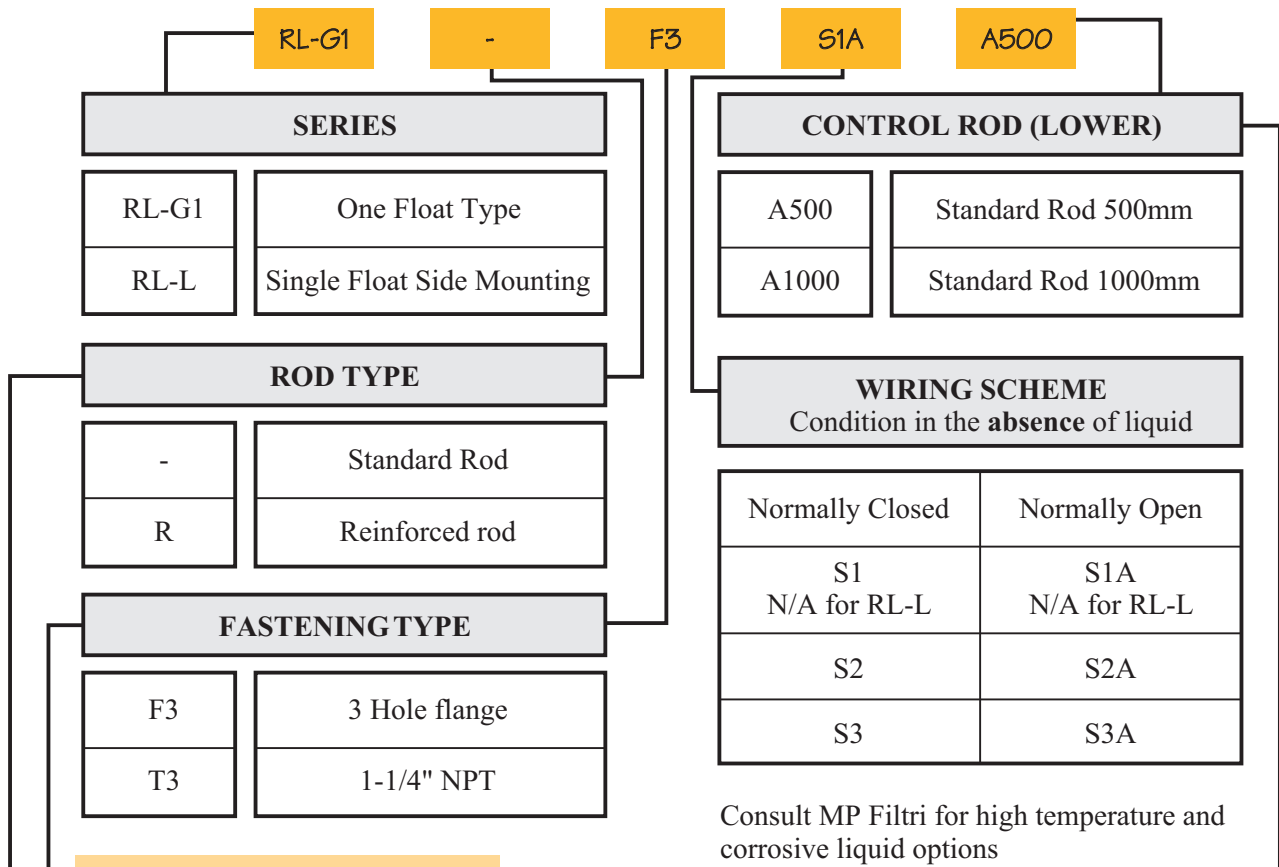

Double Float

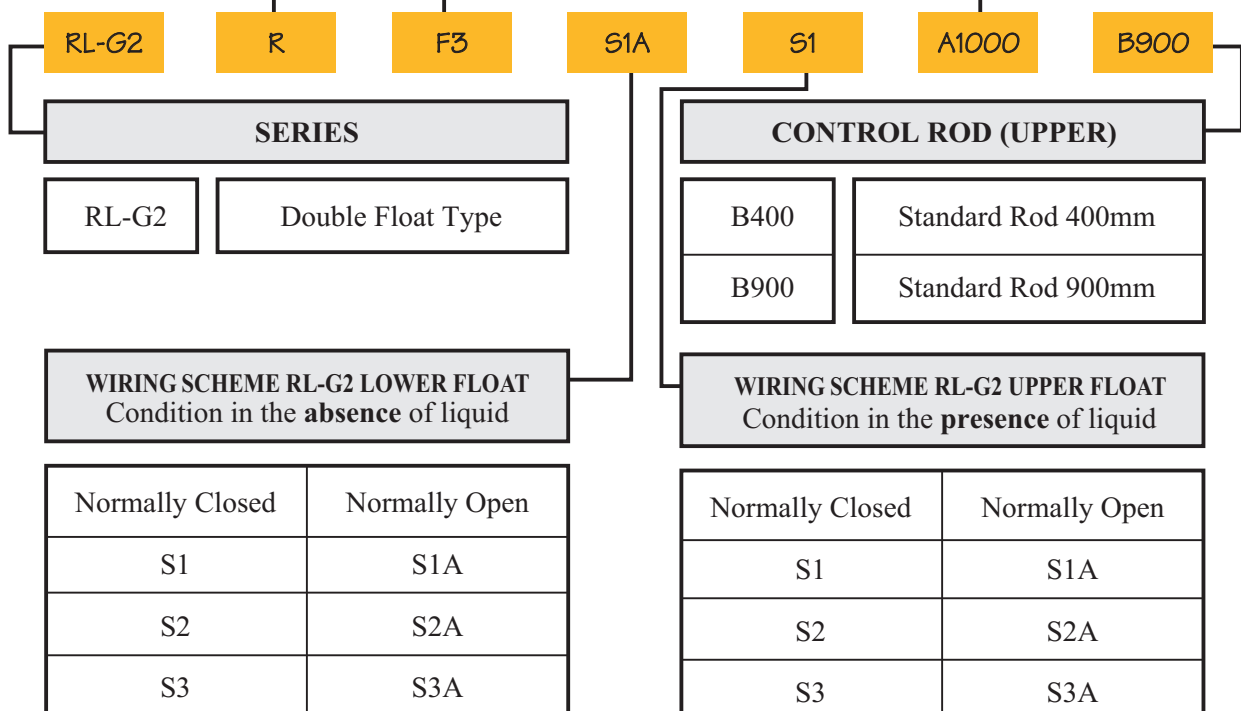

Visual Indicator and Electrical Level Switch - LV/E1 Series



Description

- ◆ One part provides two functions, visual level indicator and electrical low level switch which reduces costs.
- ◆ All electrical components are mounted outside of the tank, totally isolated from the liquid.
- ◆ U shaped shield protects sight gauge
- ◆ Graduated scale for locating level of liquid.
- ◆ Available in 5" and 10" lengths.
- ◆ Available as "Normally Open" (NO) or Exchange Contacts (NO) or (NC) in the presence of liquid. Single Pole Single Throw (SPST) contact.
- ◆ Switch specifications: 1A, 20W, 200V. Externally mounted, magnetically operated reed switch.
- ◆ Optional probe thermometer.

Dimensions

Size	A	B	C	D
LV/E1 - 127	153 mm 6.023"	35 mm 1.379"	13 mm 0.512"	127 mm 5.00"
LV/E1 - 254	280 mm 11.02"	35 mm 1.379"	13 mm 0.512"	254 mm 10.00"

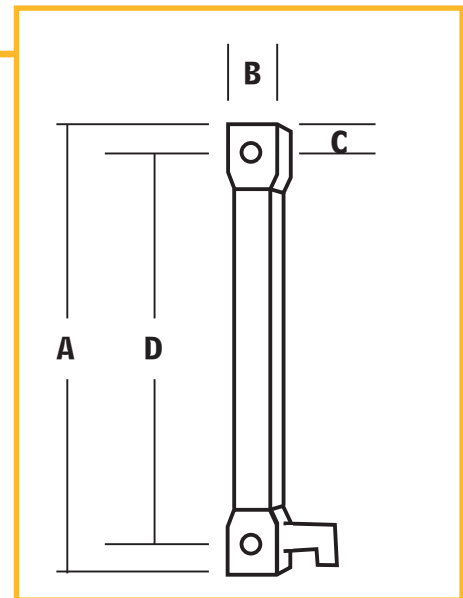

Ordering Information

Description*	5" Visual/Electrical Gauge	10" Visual/Electrical Gauge
Normally Open Contacts (NO)	LV/E1 - 127 - M12 - NO	LV/E1 - 254 - M12 - NO
Exchange Contacts	LV/E1 - 127 - M12 - Change	LV/E1 - 254 - M12 - Change
Normally Open Contacts (NO) with temperature probe	LV/E1 - 127 - M12 - NO - T	LV/E1 - 254 - M12 - NO - T
Exchange Contacts with temperature probe	LV/E1 - 127 - M12 - Change - T	LV/E1 - 254 - M12 - Change - T

* Condition in the presence of liquid